

ISO Cylinders

ø32, ø40, ø50, ø63, ø80, ø100, ø125

- CNOMO and circular grooves are set on all four sides.
- Switch can slide in.



Profile Design ISO Cylinder
Series CP96



Series C96

Variations

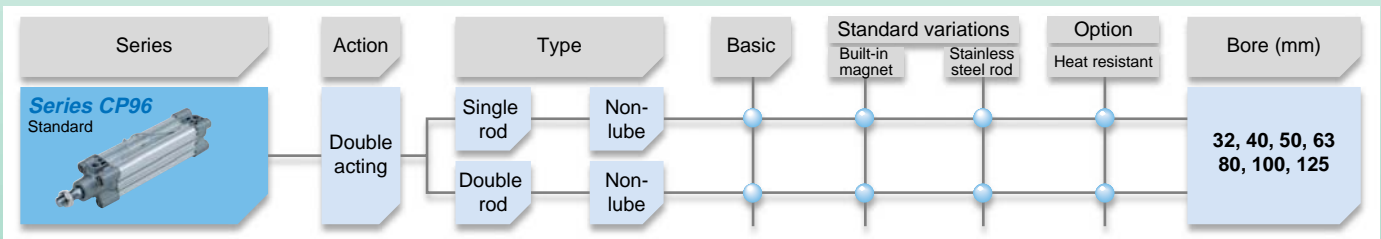

Variations

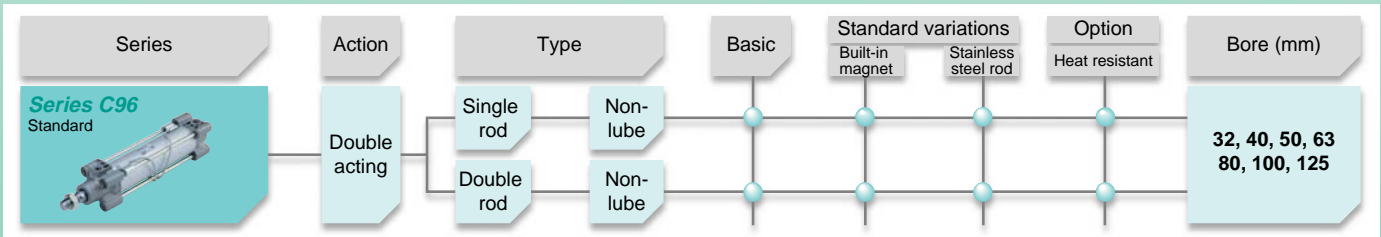

Series CP96/C96



CAT.ES20-204A

Profile Design ISO Cylinder

Series CP96

ø32, ø40, ø50, ø63, ø80, ø100, ø125

Profile design with enclosed tie-rods



Variations

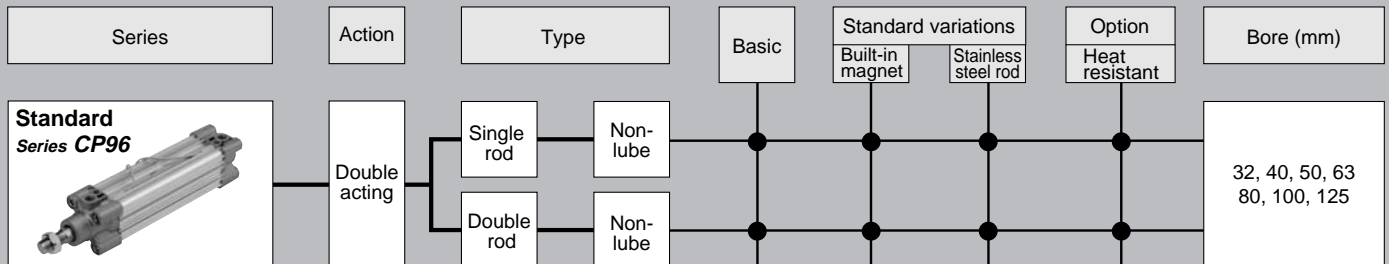

Series CP96

Improved end of stroke cushion capacity

Piston rod lurching has been eliminated at the end of stroke positions by means of a floating seal mechanism.

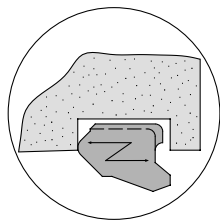

Air cylinder Compact and light design

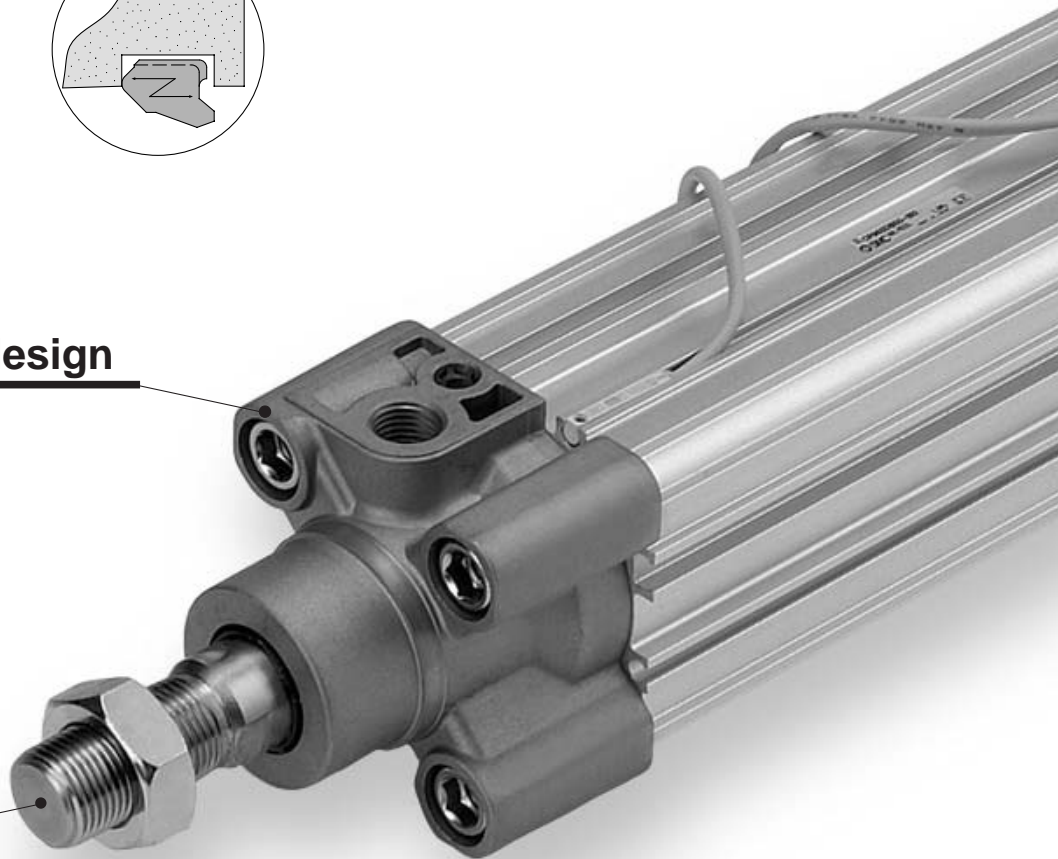

Improved mounting accuracy

High accuracy covers and tie rod nuts simplify the mounting process and also extend cylinder life.

Piston rod deflection reduced

Deflection of the piston rod has been reduced by increasing the precision of the bushing and piston rod, and reducing the tolerances.

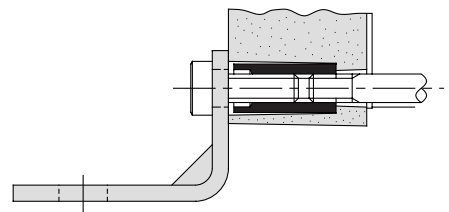

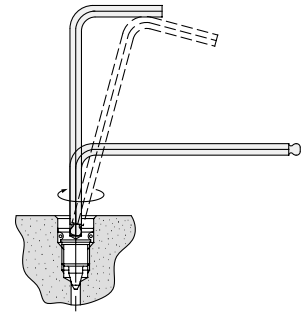

Port aperture

Easy end of stroke cushion valve adjustment

Since adjustment of the cushion valve is performed with a hexagon wrench key, even fine control can be easily accomplished. Furthermore, the cushion valve has been recessed so that it does not protrude from the cover.

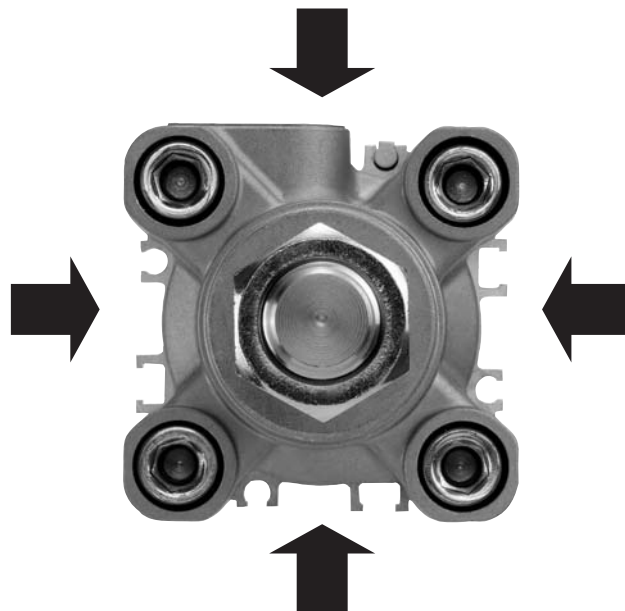

- CNOMO and circular grooves are set on all four sides.
- Switch can slide in.

ISO Cylinder: Standard Double Acting with End of Stroke Cushioning Series CP96

ø32, ø40, ø50, ø63, ø80, ø100, ø125

How to Order

Without auto switch

CP96S B 32 100 W

With auto switch

CP96SD B 32 100 W M9BW S

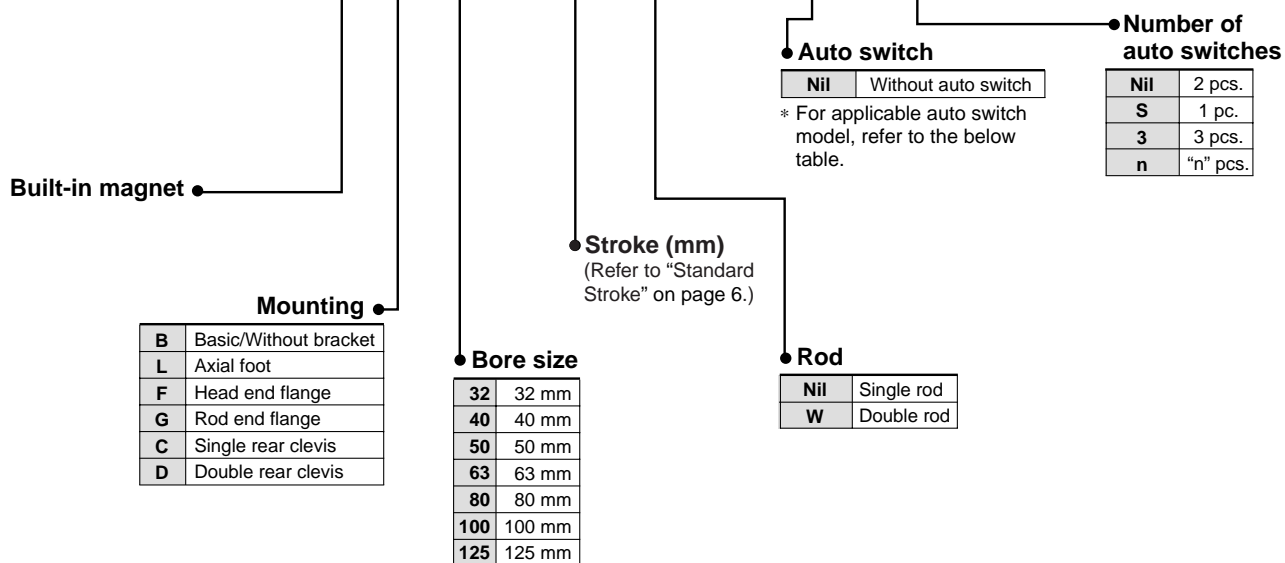

Applicable Auto Switches/Tie-rod Mounting

Type	Special function	Electrical entry	Indicator light	Wiring (Output)	Load voltage		Auto switch model	Lead wire length (m)				Pre-wired connector	Applicable load		
					DC	AC		0.5 (Nil)	1 (M)	3 (L)	5 (Z)		IC	Relay, PLC	
Solid state switch	—	Grommet	—	3-wire (NPN)	24 V	5 V, 12 V	—	** M9N	●	●	●	○	○	IC	Relay, PLC
				3-wire (PNP)				** M9P	●	●	●	○			
				2-wire				** M9B	●	●	●	○			
				3-wire (NPN)				M9NW	●	●	●	○			
	Diagnosis indication (2-color)	Grommet	Yes	3-wire (PNP)	5 V, 12 V	—	M9PW	●	●	●	○	○	IC		
				2-wire			M9BW	●	●	●	○	○	—		
	Water resistant (2-color)	Grommet	—	3-wire (NPN)	24 V	5 V, 12 V	—	M9NA	○	○	●	○	○	IC	
				3-wire (PNP)				M9PA	○	○	●	○	○	—	
				2-wire				M9BA	○	○	●	○	○	—	
				2-wire				A96	●	—	●	—	—	—	
Reed switch	—	Grommet	Yes	3-wire (Equiv. to NPN)	24 V	12 V	100 V or less	A93	●	—	●	—	—	—	Relay, PLC
				2-wire				A90	●	—	●	—	—	—	IC

* Lead wire length symbols: 0.5 m Nil (Example) M9NW
 1 m M (Example) M9NWM
 3 m L (Example) M9NWL
 5 m Z (Example) M9NWX

* Solid state switches marked with "○" are produced upon receipt of order.

* Since there are other applicable auto switches than listed, refer to SMC "Best Pneumatics 2004" Vol.7/8/9/10 catalog.
 * For details about auto switches with pre-wired connector, refer to SMC "Best Pneumatics 2004" Vol.6 catalog.
 * D-A9□, M9□, M9□W, M9□AL are shipped together, (but not assembled).
 (Switch mounting bracket is only assembled at the time of shipment.)
 ** D-M9BM, M9NM, M9PM type (product of 1 m in length of the lead wire) are applicable from the shipment in May, 2008.
 Note) D-Y59A, Y69A, Y7P, Y7□W, Z7□, Z80 type cannot be mounted on the CP96 series.
 Moreover, D-M9□□ and A9□ type cannot be mounted on square groove of the CP96 series.

Accessories

Cylinder Mounting Accessories

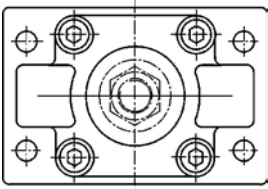
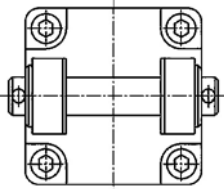
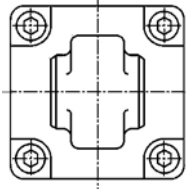
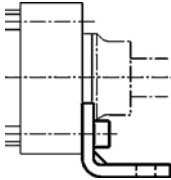
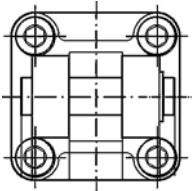
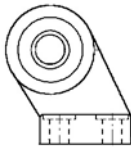
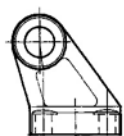
Bore size (mm)	F Rod/Head end flange	D Female head end clevis (Corresponds to E accessory)	C Male head end clevis	
				
	Supplied with 4 screws.	Supplied with bolt, safety device and 4 screws.	Supplied with 4 screws.	
			Plain	With ball joint
32	F5032	D5032	C5032	CS5032
40	F5040	D5040	C5040	CS5040
50	F5050	D5050	C5050	CS5050
63	F5063	D5063	C5063	CS6063
80	F5080	D5080	C5080	CS5080
100	F5100	D5100	C5100	CS5100
125	F5125	D5125	C5125	CS5125
	Page 10 for dimensions.	Page 10 and 11 for dimensions.	Page 10 and 11 for dimensions.	
Bore size (mm)	L Foot	DS Female head end clevis (for ES accessory)	ES Angled head end clevis with ball joint	E Angled head end clevis
				
	Supplied with 2 pieces.			
32	L5032	DS5032	ES5032	E5032
40	L5040	DS5040	ES5040	E5040
50	L5050	DS5050	ES5050	E5050
63	L5063	DS5063	ES5063	E5063
80	L5080	DS5080	ES5080	E5080
100	L5100	DS5100	ES5100	E5100
125	L5125	DS5125	ES5125	E5125
	Page 10 for dimensions.	Page 12 for dimensions.	Page 12 for dimensions.	Page 11 for dimensions.

Piston Rod Mounting Accessories

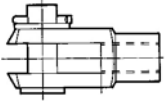
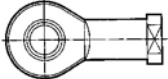
Bore size (mm)	GKM Rod clevis (ISO 8140)	KJ Piston rod ball joint (ISO 8139)	JA Floating joint
			
	Supplied with bolt and safety device.		
32	GKM10-20	KJ10D	JA30-10-125
40	GKM12-24	KJ12D	JA40-12-125
50	GKM16-32	KJ16D	JA50-16-150
63	GKM16-32	KJ16D	JA50-16-150
80	GKM20-40	KJ20D	JAH50-20-150
100	GKM20-40	KJ20D	JAH50-20-150
125	GKM30-54	KJ27D	JA125-27-200
	Page 13 for dimensions.	Page 13 for dimensions.	Page 13 for dimensions.

Series CP96

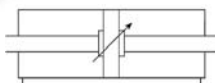
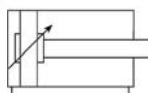

Minimum Stroke for Auto Switch Mounting

Refer to page 14 for "Minimum Stroke for Auto Switch Mounting".

Specifications

Bore size (mm)	32	40	50	63	80	100	125
Action	Double acting						
Fluid	Air						
Proof pressure	1.5 MPa						
Max. operating pressure	1.0 MPa						
Min. operating pressure	0.05 MPa						
Ambient and fluid temperature	Without auto switch: -20 to 70°C With auto switch: -10 to 60°C						
Lubrication	Not required (Non-lube)						
Operating piston speed	50 to 1000 mm/s					50 to 700 mm/s	
Allowable stroke tolerance	Up to 250 st: $^{+1.0}_0$, 251 to 1000 st: $^{+1.4}_0$, 1001 to 1500 st: $^{+1.8}_0$, 1501 to 2000 st: $^{+2.2}_0$						
Cushion	Both ends (Air cushion)						
Port size	G 1/8	G 1/4	G 1/4	G 3/8	G 3/8	G 1/2	G 1/2
Mounting	Basic, Axial foot, Rod end flange, Head end flange, Single clevis, Double clevis, Center trunnion						

Standard Stroke

Bore size (mm)	Standard stroke (mm)	Max. * stroke
32	25, 50, 80, 100, 125, 160, 200, 250, 320, 400, 500	2000
40	25, 50, 80, 100, 125, 160, 200, 250, 320, 400, 500	2000
50	25, 50, 80, 100, 125, 160, 200, 250, 320, 400, 500, 600	2000
63	25, 50, 80, 100, 125, 160, 200, 250, 320, 400, 500, 600	2000
80	25, 50, 80, 100, 125, 160, 200, 250, 320, 400, 500, 600, 700, 800	2000
100	25, 50, 80, 100, 125, 160, 200, 250, 320, 400, 500, 600, 700, 800	2000
125	—	2000

Intermediate strokes are available.

* Please consult with SMC for longer strokes.

Accessories

Mounting		Basic	Foot	Rod end flange	Head end flange	Single clevis	Double clevis	Center trunnion
Standard	Rod end nut	●	●	●	●	●	●	●
	Clevis pin	—	—	—	—	—	●	—
Option	Piston rod ball joint	●	●	●	●	●	●	●
	Rod clevis	●	●	●	●	●	●	●
	Rod boot	●	●	●	●	●	●	●

* Please do not use a piston rod ball joint (or floating joint) together with a head end clevis with a ball joint (or angled head end clevis with a ball joint).

ISO Cylinder: Standard Double Acting w/ End of Stroke Cushioning **Series CP96**

Theoretical Output



Allowable Kinetic Energy

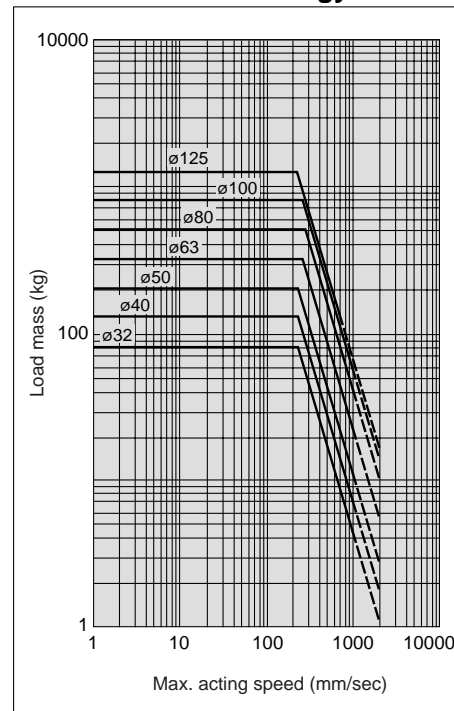

Example: Load limit at rod end when air cylinder ø63 is actuated with max. actuating speed 500 mm/s. See the intersection of lateral axis 500 mm/s and ø63 line, and extend the intersection to left. Thus, the allowable load is 80 kg.

Bore size (mm)	Rod diameter (mm)	Operating direction	Piston area (mm ²)	Operating pressure (MPa)								
				0.2	0.3	0.4	0.5	0.6	0.7	0.8	0.9	1.0
32	12	OUT	804	161	241	322	402	482	563	643	724	804
		IN	691	138	207	276	346	415	484	553	622	691
40	16	OUT	1257	251	377	503	629	754	880	1006	1131	1257
		IN	1056	211	317	422	528	634	739	845	950	1056
50	20	OUT	1963	393	589	785	982	1178	1374	1570	1767	1963
		IN	1649	330	495	660	825	989	1154	1319	1484	1649
63	20	OUT	3117	623	935	1247	1559	1870	2182	2494	2805	3117
		IN	2803	561	841	1121	1402	1682	1962	2242	2523	2803
80	25	OUT	5027	1005	1508	2011	2514	3016	3519	4022	4524	5027
		IN	4536	907	1361	1814	2268	2722	3175	3629	4082	4536
100	25	OUT	7854	1571	2356	3142	3927	4712	5498	6283	7068	7854
		IN	7363	1473	2209	2945	3682	4418	5154	5890	6627	7363
125	32	OUT	12272	2454	3682	4909	6136	7363	8590	9817	11045	12272
		IN	11468	2294	3440	4587	5734	6881	8027	9174	10321	11468

Note) Theoretical out put (N) = Pressure (MPa) x Piston area (mm²)

Mass

(kg)

Bore size (mm)		32	40	50	63	80	100	125
Basic mass	Basic	0.55	0.84	1.36	1.77	2.84	3.77	6.82
	Foot	0.16	0.20	0.38	0.46	0.89	1.09	2.60
	Flange	0.20	0.23	0.47	0.58	1.30	1.81	4.10
	Single clevis	0.16	0.23	0.37	0.60	1.07	1.73	4.15
	Double clevis	0.20	0.32	0.45	0.71	1.28	2.11	4.25
	Trunnion	0.71	1.10	1.73	2.48	4.25	5.95	2.98
Additional mass per each 50 mm stroke	All mounting brackets	0.14	0.18	0.30	0.32	0.49	0.54	0.84
Accessory	Single rod clevis	0.07	0.11	0.22		0.40		1.20
	Double rod clevis	0.09	0.15	0.34		0.69		1.84

Calculation: (Example) CP96SD40-100

- Basic mass 0.84 (kg) (Basic, ø40)
 - Additional mass 0.18 (kg/50 st)
 - Cylinder stroke 100 (st)
 - Mounting 0.32 (kg) (Double clevis)
- 0.84 + 0.18 x 100 ÷ 50 + 0.32 = 1.52 kg

Series CP96

Construction

[First angle projection]

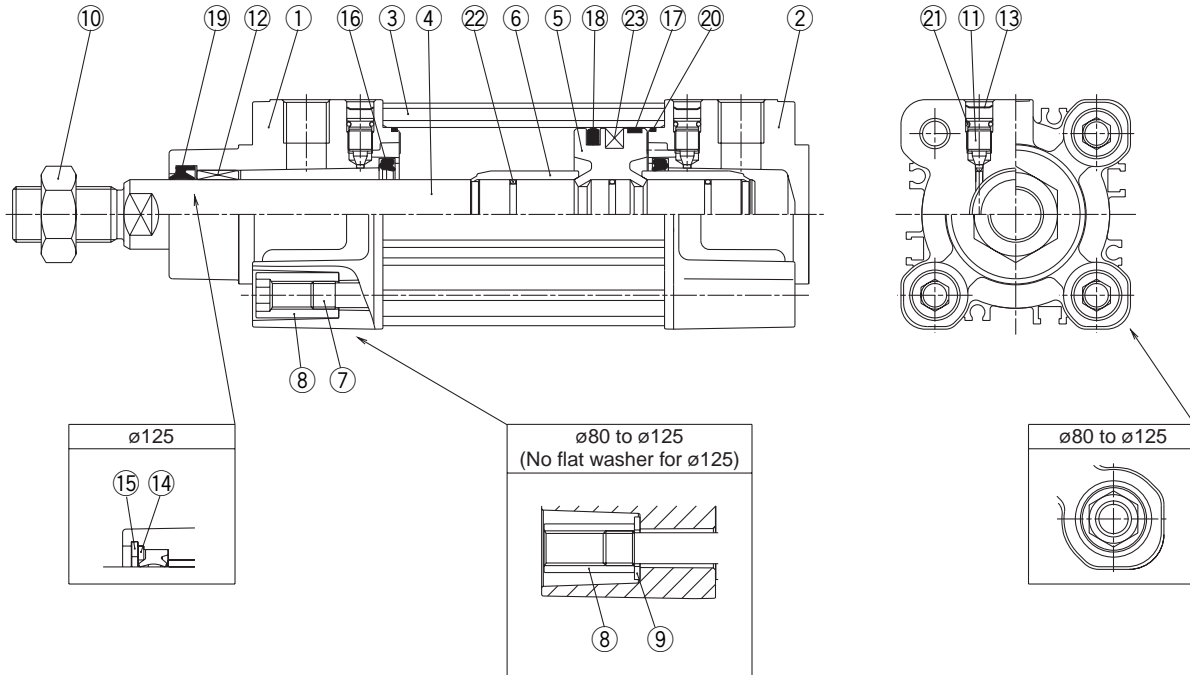

Component Parts

No.	Description	Material	Note
①	Rod cover	Aluminum die-casted	
②	Head cover	Aluminum die-casted	
③	Cylinder tube	Aluminum alloy	
④	Piston rod	Carbon steel	
⑤	Piston	Aluminum alloy	
⑥	Cushion ring	Brass	
⑦	Tie-rod	Carbon steel	
⑧	Tie-rod nut	Steel	
⑨	Flat washer	Steel	ø80 and ø100
⑩	Rod end nut	Steel	
⑪	Cushion valve	Steel wire	
⑫	Bushing	Sintered metal	
⑬	Snap ring	Steel for spring	ø40 to ø125
⑭	Rod seal holder	Stainless steel	ø125
⑮	Snap ring	Steel for spring	ø125
⑯	Cushion seal	Urethane rubber	
⑰	Wearing	Resin	
⑱	Piston seal	NBR	
⑲	Rod seal	NBR	
⑳	Cylinder tube gasket	NBR	
㉑	Cushion valve seal	NBR	
㉒	Piston gasket	NBR	
㉓	Magnet		

Replacement Parts: Seal Kit

Bore size (mm)	Kit no.	Contents
32	CS95-32	Kits include items ⑯ to ㉑.
40	CS95-40	
50	CS95-50	
63	CS95-63	
80	CS95-80	
100	CS96-100	
125	CS96-125	

* Seal kits consist of items ⑯ to ㉑ contained in one kit, and can be ordered using the number for each respective tube bore size.

ISO Cylinder: Standard Double Acting w/ End of Stroke Cushioning **Series CP96**

Dimensions: Without Mounting Bracket

[First angle projection]

CP96S(D)B Bore size Stroke

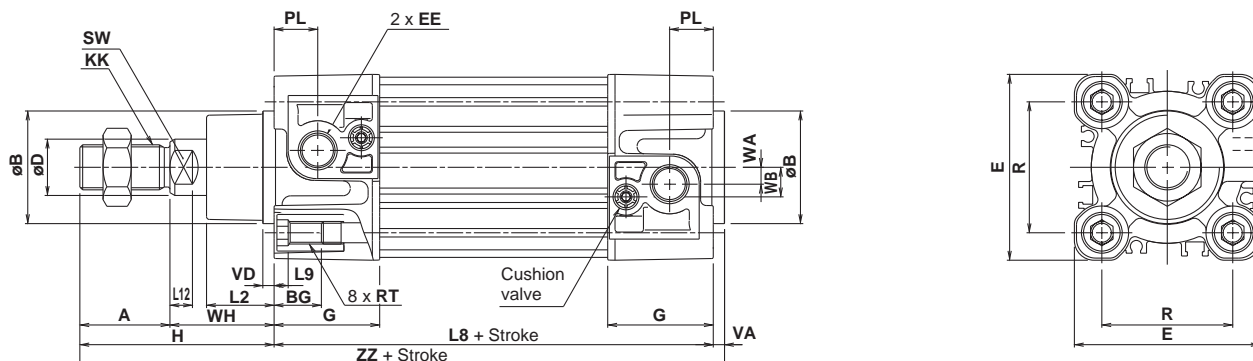

CP96S(D)B Bore size Stroke **W**

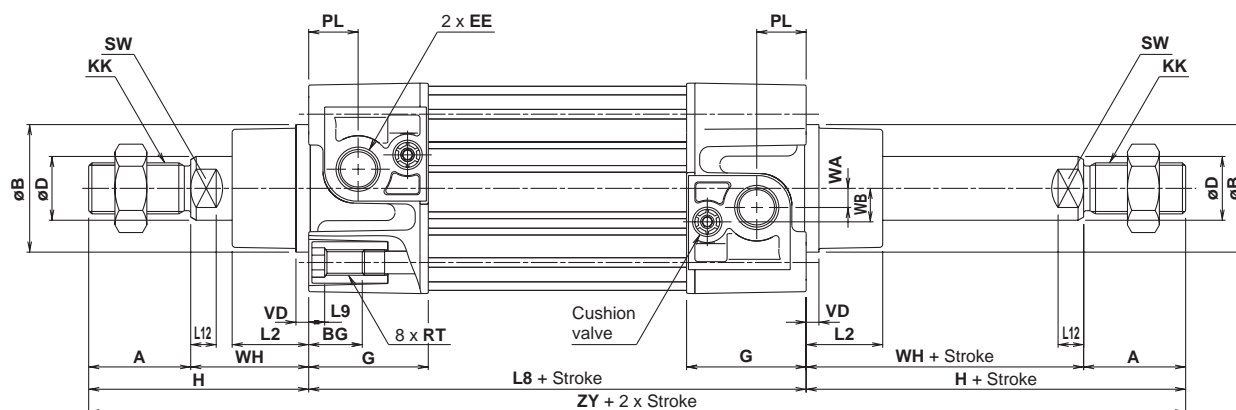

Bore size (mm)	A	ϕB d11	ϕD	EE	PL	RT	L12	KK	SW	G	BG	L8	VD	VA	WA	WB	WH	ZZ	ZY	E	R	L2	L9	H
32	22	30	12	G 1/8	13	M6 x 1	6	M10 x 1.25	10	32	16	94	4	4	4	7	26	146	190	47	32.5	15	4	48
40	24	35	16	G 1/4	14	M6 x 1	6.5	M12 x 1.25	13	37.5	16	105	4	4	5	9	30	163	213	54	38	17	4	54
50	32	40	20	G 1/4	15.5	M8 x 1.25	8	M16 x 1.5	17	37.5	16	106	4	4	6	10.5	37	179	244	66	46.5	24	5	69
63	32	45	20	G 3/8	16.5	M8 x 1.25	8	M16 x 1.5	17	45	16	121	4	4	9	12	37	194	259	77	56.5	24	5	69
80	40	45	25	G 3/8	19	M10 x 1.5	10	M20 x 1.5	22	45	17	128	4	4	11.5	14	46	218	300	99	72	30	—	86
100	40	55	25	G 1/2	19	M10 x 1.5	10	M20 x 1.5	22	50	17	138	4	4	17	15	51	233	320	118	89	32	—	91
125	54	60	32	G 1/2	19	M12 x 1.75	13	M27 x 2	27	58	20	160	6	6	17	15	65	285	398	144	110	40	—	119

Series CP96

Dimensions: Cylinder Mounting Accessories (L/F/G/C/D)

[First angle projection]

Mounting (L)

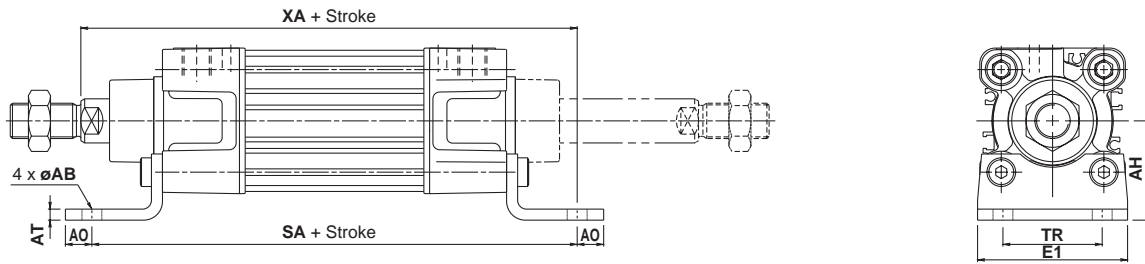

Mounting (F/G)

Head end mounting (G)

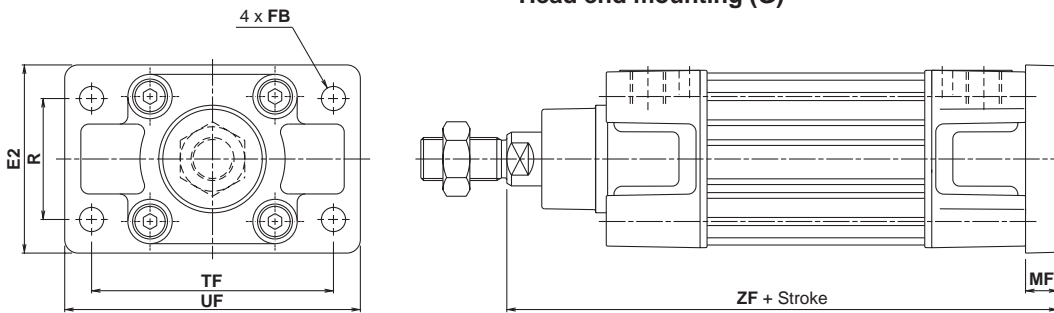

Rod end mounting (F)

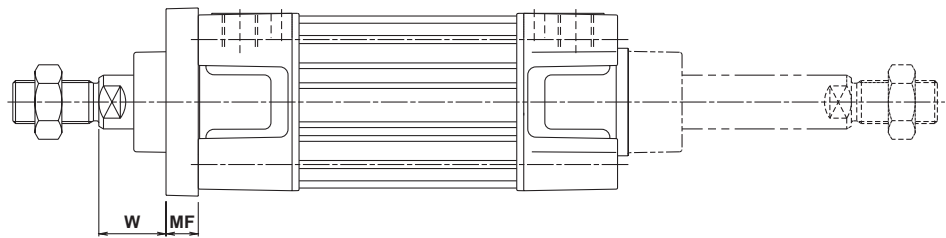

Mounting (C)

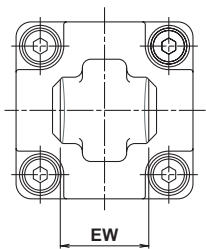

Mounting (D)

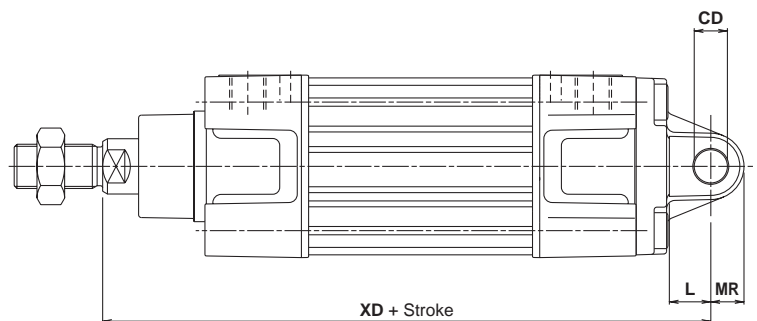
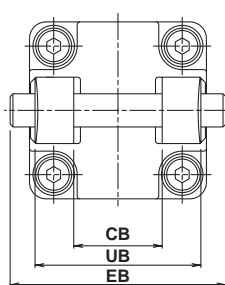

Bore size (mm)	E1	TR	AH	AO	AT	øAB	SA	XA	R	TF	øFB	E2	UF	W	MF	ZF	UB h14	CB H14	EW	øCD H9	L	MR	XD	EB
32	48	32	32	10	4.5	7	142	144	32	64	7	50	79	16	10	130	45	26	26-0.2/-0.6	10	12	9.5	142	65
40	55	36	36	11	4.5	10	161	163	36	72	9	55	90	20	10	145	52	28	28-0.2/-0.6	12	15	12	160	75
50	68	45	45	12	5.5	10	170	175	45	90	9	70	110	25	12	155	60	32	32-0.2/-0.6	12	15	12	170	80
63	80	50	50	12	5.5	10	185	190	50	100	9	80	120	25	12	170	70	40	40-0.2/-0.6	16	20	16	190	90
80	100	63	63	14	6.5	12	210	215	63	126	12	100	153	30	16	190	90	50	50-0.2/-0.6	16	20	16	210	110
100	120	75	71	16	6.5	14.5	220	230	75	150	14	120	178	35	16	205	110	60	60-0.2/-0.6	20	25	20	230	140
125	Max. 157	90	90	Max. 25	8	16	250	270	90	180	16	Max. 157	Max. 224	45	20	245	130	70	70-0.5/-1.2	25	Min. 30	Max. 26	275	Max. 157

Dimensions: Cylinder Mounting Accessories (C/D/E/CS)

[First angle projection]

Mounting (C)

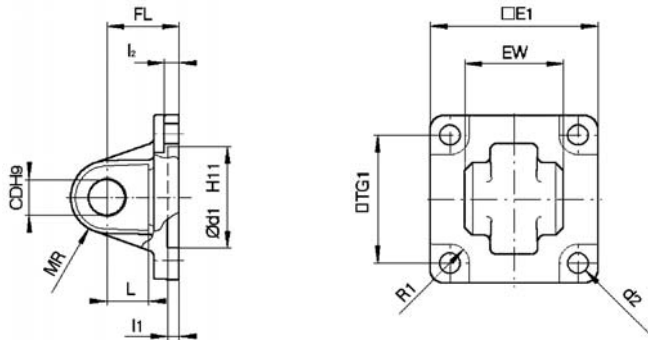

Mounting (D)

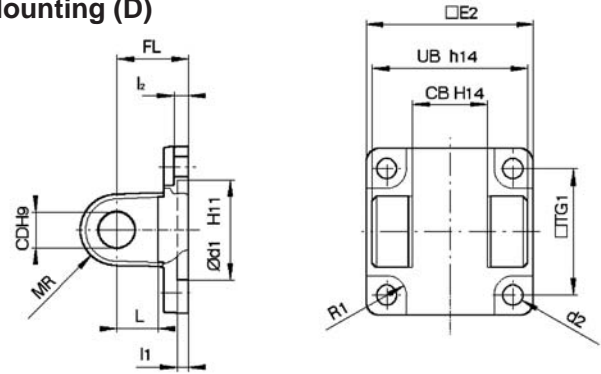

Bore size (mm)	E ₁	EW	TG ₁	FL	l ₁	L	l ₂	ød ₁	øCD	MR	ød ₂	R ₁	E ₂	UB	CB
32	45	26 ^{-0.2} _{-0.6}	32.5	22	5	12	5.5	30	10	9.5	6.6	6.5	48	45	26
40	51	28 ^{-0.2} _{-0.6}	38	25	5	15	5.5	35	12	12	6.6	6.5	56	52	28
50	64	32 ^{-0.2} _{-0.6}	46.5	27	5	15	6.5	40	12	12	9	8.5	64	60	32
63	74	40 ^{-0.2} _{-0.6}	56.5	32	5	20	6.5	45	16	16	9	8.5	75	70	40
80	94	50 ^{-0.2} _{-0.6}	72	36	5	20	10	45	16	16	11	11	95	90	50
100	113	60 ^{-0.2} _{-0.6}	89	41	5	25	10	55	20	20	11	12	115	110	60
125	Max. 157	70 ^{-0.5} _{-1.2}	110	50	7	30	10	60	25	26	13.5	10	Max. 157	130	70

Mounting (E)

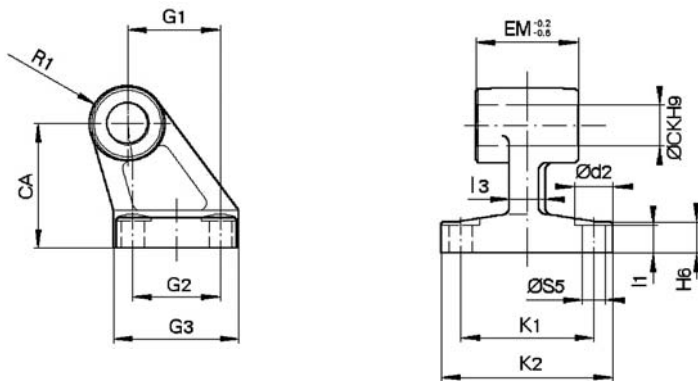

Bore size (mm)	ød ₂	øCK	øS5	K ₁	K ₂ max.	l ₃ max.	G ₁	l ₁	G ₂	EM	G ₃ max.	CA	H ₆	R ₁
32	11	10	6.6	38	51	10	24	9	22	26 ^{-0.2} _{-0.6}	31	32	8	10
40	11	12	6.6	41	54	10	24	9	22	28 ^{-0.2} _{-0.6}	35	36	10	11
50	15	12	9	50	65	12	33	11	30	32 ^{-0.2} _{-0.6}	45	45	12	12
63	15	16	9	52	67	14	37	11	35	40 ^{-0.2} _{-0.6}	50	50	12	15
80	18	16	11	66	86	18	47	12.5	40	50 ^{-0.2} _{-0.6}	60	63	14	15
100	18	20	11	76	96	20	55	13.5	50	60 ^{-0.2} _{-0.6}	70	71	15	19
125	20	25	14	94	124	30	70	17	60	70 ^{-0.5} _{-1.5}	90	90	20	22.5

Mounting (CS): Head end clevis with ball joint

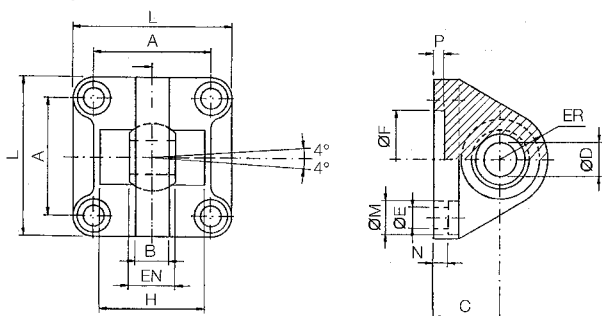

Bore size (mm)	A	B max.	C	øD H7	EN 0-0.1	ER max.	øF H11	øE	L	øM	N	P	H ±0.5
32	32.5	10.5	22	10	14	15	30	6.6	45	10.5	5.5	5	—
40	38	12	25	12	16	18	35	6.6	55	11	5.5	5	—
50	46.5	15	27	16	21	20	40	9	65	15	6.5	5	51
63	56.5	15	32	16	21	23	45	9	75	15	6.5	5	—
80	72	18	36	20	25	27	45	11	95	18	10	5	70
100	89	18	41	20	25	30	55	11	115	18	10	5	—
125	110	25	50	30	37	40	60	13.5	140	20	10	7	100

* Black color



Series CP96

Dimensions: Cylinder Mounting Accessories (DS/ES)

[First angle projection]

Mounting (DS)

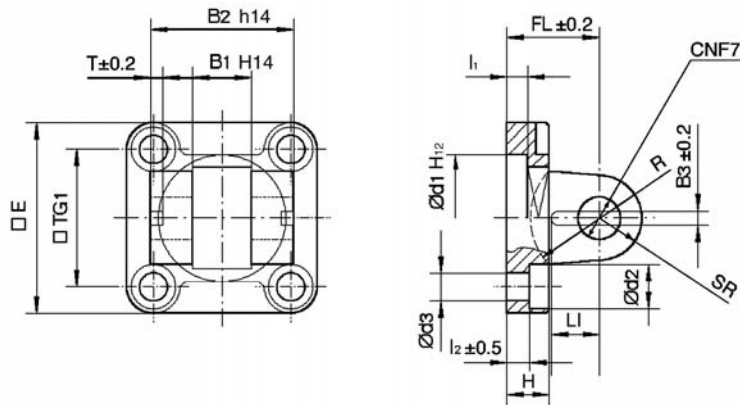

Bore size (mm)	E	B ₁	B ₂	B ₃	LI	TG ₁	T	l ₁ min.	l ₂	FL	H max.	Ød ₁	Ød ₂	Ød ₃	ØCN	SR max.	R
32	45	14	34	3.3	11.5	32.5	3	5	5.5	22	10	30	10.5	6.6	10	11	17
40	55	16	40	4.3	12	38	4	5	5.5	25	10	35	11	6.6	12	13	20
50	65	21	45	4.3	14	46.5	4	5	6.5	27	12	40	15	9	16	18	22
63	75	21	51	4.3	14	56.5	4	5	6.5	32	12	45	15	9	16	18	25
80	95	25	65	4.3	16	72	4	5	10	36	16	45	18	11	20	22	30
100	115	25	75	6.3	16	89	4	5	10	41	16	55	18	11	20	22	32
125	140	37	97	6.3	24	110	6	7	10	50	20	60	20	13.5	30	30	42

* Black color

Mounting (ES)

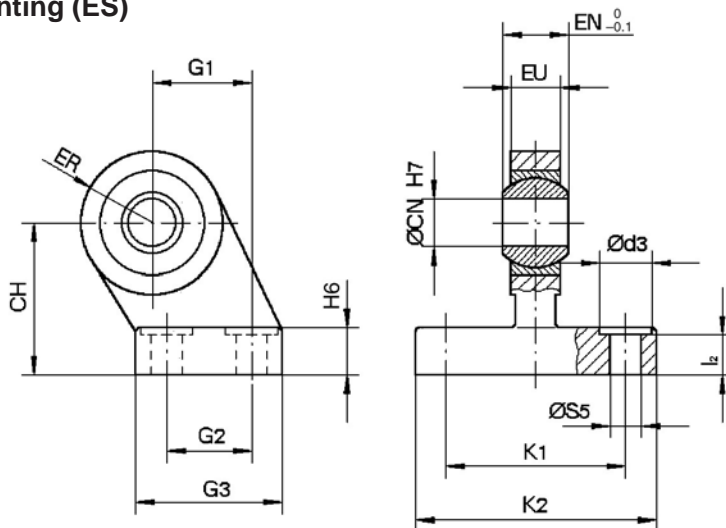

Bore size (mm)	Ød ₃	ØCN	ØS ₅	K ₁	K ₂ max.	l ₂	G ₁	G ₂	G ₃ max.	EN	EU	CH	H ₆	ER max.
32	11	10	6.6	38	51	8.5	21	18	31	14	10.5	32	10	15
40	11	12	6.6	41	54	8.5	24	22	35	16	12	36	10	18
50	15	16	9	50	65	10.5	33	30	45	21	15	45	12	20
63	15	16	9	52	67	10.5	37	35	50	21	15	50	12	23
80	18	20	11	66	86	11.5	47	40	60	25	18	63	14	27
100	18	20	11	76	96	12.5	55	50	70	25	18	71	15	30
125	20	30	13.5	94	124	17	70	60	90	37	25	90	20	40

* Black color

Dimensions: Piston Rod Mounting Accessories

[First angle projection]

Floating Joint JA

Bore size (mm)	M	Part no.	A	B	C	∅D	E	F	G	H	P	U	Load (kN)	Mass (g)	Angle
32	M10 x 1.25	JA30-10-125	49.5	19.5	—	24	5	8	8	17	9	0.5	2.5	70	±0.5°
40	M12 x 1.25	JA40-12-125	60	20	—	31	6	11	11	22	13	0.75	4.4	160	
50, 63	M16 x 1.5	JA50-16-150	71.5	22	—	41	7.5	14	13.5	27	15	1	11	300	
80, 100	M20 x 1.5	JAH50-20-150	101	28	31	59.5	11.5	24	16	32	18	2	18	1080	
125	M27 x 2	JA125-27-200	123	34	38	66	13	27	20	41	24	2	28	1500	

* Black color

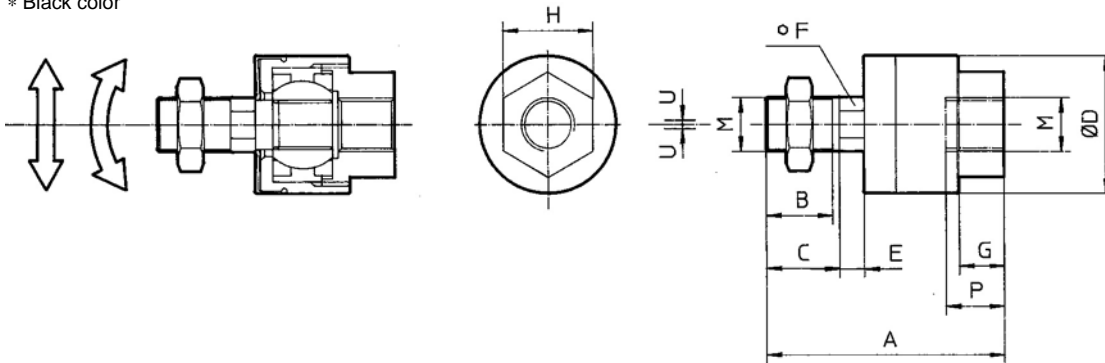

Rod Clevis GKM (ISO 8140), Supplied with Bolt and Safety Device

Bore size (mm)	e	Part no.	b	d	∅f h11 (Shaft)	∅f H9 (Hole)	l1	c min.	a max.
32	M10 x 1.25	GKM10-20	10 ^{+0.5} / _{+0.15}	40	10	10	52	20	20
40	M12 x 1.25	GKM12-24	12 ^{+0.5} / _{+0.15}	48	12	12	62	24	24
50, 63	M16 x 1.5	GKM16-32	16 ^{+0.5} / _{+0.15}	64	16	16	83	32	32
80, 100	M20 x 1.5	GKM20-40	20 ^{+0.5} / _{+0.15}	80	20	20	105	40	40
125	M27 x 2	GKM30-54	30 ^{+0.5} / _{+0.15}	110	30	30	148	54	55

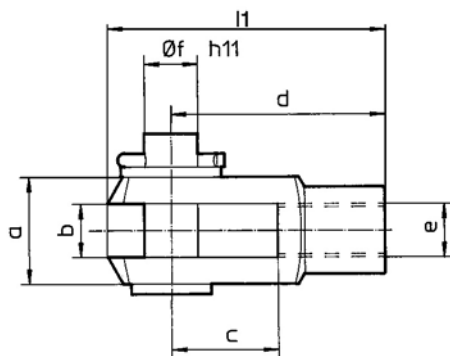

Piston Rod Ball Joint KJ (ISO 8139)

Bore size (mm)	d3	Part no.	∅d1 H9	h	d6 max.	b1 h12	l min.	α	l3
32	M10 x 1.25	KJ10D	10	43	28	14	20	4°	15
40	M12 x 1.25	KJ12D	12	50	32	16	22	4°	17
50, 63	M16 x 1.5	KJ16D	16	64	42	21	28	4°	23
80, 100	M20 x 1.5	KJ20D	20	77	50	25	33	4°	27
125	M27 x 2	KJ27D	30	110	70	37	51	4°	36

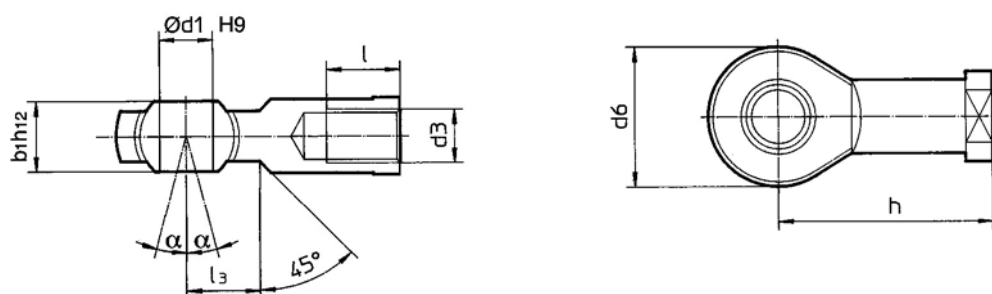

Series CP96

Minimum Stroke for Auto Switch Mounting



(mm)

Auto switch model	Number of auto switch mounted	32	40	50	63	80	100	125	
D-M9□	2 switches (Different side, Same side)	15				10			
	1 switch	15				10			
	Other qty.	15+5 (n-2)				10+10 (n-2)			
D-M9□W D-M9□AL	2 switches (Different side, Same side)	15				10			
	1 switch	15				10			
	Other qty.	15+10 (n-2)				10+10 (n-2)		10+15 (n-2)	
D-A9□	2 switches (Different side, Same side)	15							
	1 switch	15				10			
	Other qty.	15+10 (n-2)		15+15 (n-2)			15+20 (n-2)		

* n = 3, 4, 5 ...

Recommended Mounting Position for Stroke Ends

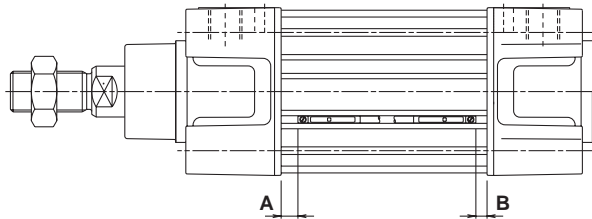
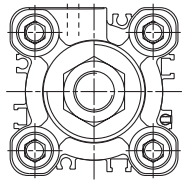

Auto Switch Proper Mounting Position

(mm)

Auto switch model Bore size	D-M9□ D-M9□W D-M9□AL		D-A9□	
	A	B	A	B
32	10.5	8	6.5	4
40	10.5	8	6.5	4
50	11	8.5	7	4.5
63	11	8.5	7	4.5
80	14	12.5	10	8.5
100	14	12.5	10	8.5
125	16	16	12	12

* Adjust the auto switch after confirming the operation to set actually.

Operating Range

(mm)

Auto switch model	Bore size						
	32	40	50	63	80	100	125
D-M9□ D-M9□W D-M9□AL	4	4.5	5	6	6	6	7.5
D-A9□	7	8	8.5	9.5	9.5	10.5	12.5

Note) Since this is a guideline including hysteresis, not meant to be guaranteed. (Assuming approximately ±30% dispersion)
There may be the case it will vary substantially depending on an ambient environment.

Besides the models listed "How to Order," the following auto switches are applicable.

* Normally closed (NC = b contact), solid state switch (D-F9G, F9H type) are also available.
For details, refer to SMC "Best Pneumatics 2004" Vol.7/8/9/10 catalog.

How to Mount and Move the Auto Switch

<Applicable Auto Switch>

Solid state switch D-M9N/M9P/M9B
D-M9NW/M9PW/M9BW
D-M9NAL/M9PAL/M9BAL
Reed switch D-A90/A93/A96

How to Mount and Move the Auto Switch

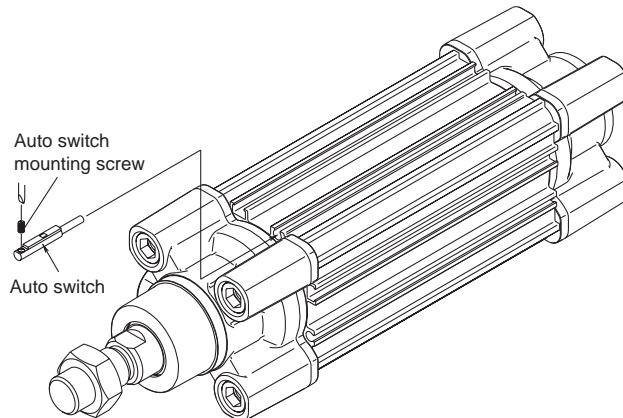

- Please use a watchmaker's screwdriver with a handle diameter of 5 to 6 mm when tightening the auto switch mounting screw. A torque of 0.05 to 0.15 N·m should be used for D-M9□, M9□W, M9□AL, and 0.10 to 0.20 N·m for D-A9□. Once the screw starts to feel tight, tighten it further by approximately another 90°.

Note) D-M9□□ and A9□ type cannot be mounted on square groove of the CP96 series.

ISO Cylinder

Series C96

ø32, ø40, ø50, ø63, ø80, ø100, ø125

Conforming to ISO 15552



Variations

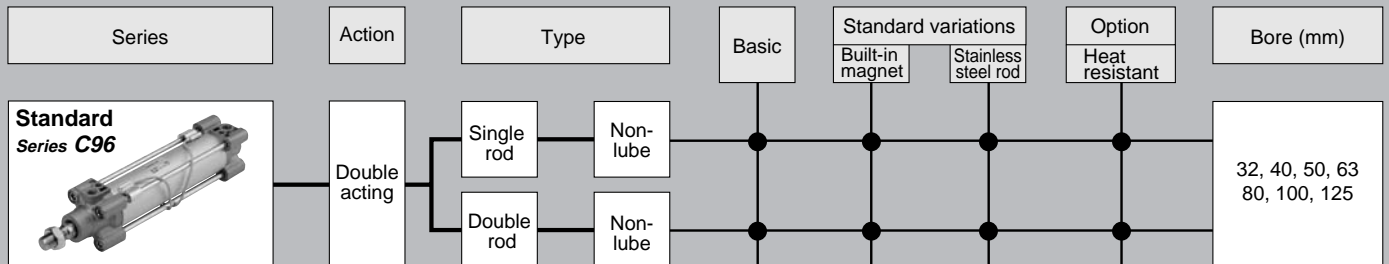

ISO Cylinder: Standard Double Acting, Single/Double Rod Series C96

ø32, ø40, ø50, ø63, ø80, ø100, ø125

How to Order

Without auto switch

C96S **B** **32** **100** **W**

With auto switch

C96SD **B** **32** **100** **W** **M9BW** **S**

Built-in magnet

Mounting

B	Basic/Without bracket
L	Axial foot
F	Rod end flange
G	Head end flange
C	Single clevis
D	Double clevis
T	Center trunnion

Bore size

32	32 mm
40	40 mm
50	50 mm
63	63 mm
80	80 mm
100	100 mm
125	125 mm

Stroke (mm)

Refer to "Standard Stroke" on page 20.

Auto switch

Nil	Without auto switch
------------	---------------------

* For applicable auto switch model, refer to the below table.

Number of auto switches

Nil	2 pcs.
S	1 pc.
3	3 pcs.
n	"n" pcs.

Rod

Nil	Single rod
W	Double rod

Applicable Auto Switches/Tie-rod Mounting

Type	Special function	Electrical entry	Indicator light	Wiring (Output)	Load voltage		Auto switch model		Lead wire length (m)				Pre-wired connector	Applicable load																							
					DC	AC	Tie-rod mounting	Band mounting	0.5 (Nil)	1 (M)	3 (L)	5 (Z)																									
Solid state switch	—	Grommet	—	3-wire (NPN)	24 V	5 V, 12 V	—	** M9N	●	●	●	○	○	IC	Relay, PLC																						
				3-wire (PNP)				** M9P	●	●	●	○	○																								
				2-wire				** M9B	●	●	●	○	○																								
		Terminal conduit		3-wire (NPN)	100 V, 200 V	5 V, 12 V	—	—	—	—	—	—	—			—	—																				
				2-wire														G39	—	—	—	—	—														
				3-wire (NPN)														K39	—	—	—	—	—														
	Diagnosis indication (2-color)	Grommet	Yes	3-wire (NPN)	24 V	5 V, 12 V	—	—	—	—	—	—	—			—	—																				
																		3-wire (PNP)	M9NW	●	●	●	○	○													
																		2-wire	M9PW	●	●	●	○	○													
	Water resistant (2-color)	Grommet	—	3-wire (NPN)	24 V	5 V, 12 V	—	—	—	—	—	—	—			—	—																				
																		3-wire (PNP)	M9BW	●	●	●	○	○													
																		2-wire	M9NA	—	○	○	●	○	○												
Diagnosis output (2-color)	Grommet	—	4-wire (NPN)	24 V	5 V, 12 V	—	—	—	—	—	—	—	—	—																							
															2-wire	M9PA	—	○	○	●	○	○															
															2-wire (Non-polar type)	M9BA	—	○	○	●	○	○															
Reed switch	—	Grommet	Yes	3-wire (Equiv. to NPN)	24 V	5 V	—	—	—	—	—	—	—	—	—																						
				None												100 V	A96	—	—	—	—	—	—	—	—	—											
																											Yes	100 V or less	A93	—	—	—	—	—	—	—	
																																					None
																											None	200 V or less	A54	—	—	—	—	—	—	—	
		Terminal conduit		2-wire	24 V	12 V	—	—	—	—	—	—	—	—	—	—																					
																	DIN	Yes	100 V, 200 V	—	—	—	—	—	—	—	—	—									
																													Grommet	—	—	—	—	—	—	—	—
																	—	—	—	—	—	—	—	—	—	—											
																											—	—									
Diagnosis indication (2-color)	Grommet	Yes	2-wire	24 V	12 V	—	—	—	—	—	—	—	—																								
														—	—	—	—	—	—	—	—	—	—	—													

* Lead wire length symbols: 0.5 m Nil (Example) M9NW
 1 m M (Example) M9NWM
 3 m L (Example) M9NWL
 5 m Z (Example) M9NWZ

* Solid state switches marked with "○" are produced upon receipt of order.

* Since there are other applicable auto switches than listed, refer to SMC "Best Pneumatics 2004" Vol.7/8/9/10 catalog.

* For details about auto switches with pre-wired connector, refer to SMC "Best Pneumatics 2004" Vol.6 catalog.

* D-A9□, M9□, M9□W, M9□AL are shipped together, (but not assembled).

(Switch mounting bracket is only assembled at the time of shipment.)

** D-M9BM, M9NM, M9PM type (product of 1 m in length of the lead wire) are applicable from the shipment in May, 2008.

Accessories

Cylinder Mounting Accessories

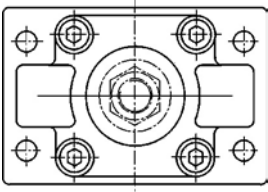
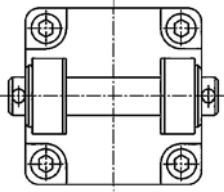
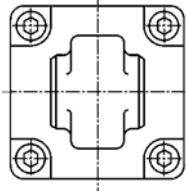
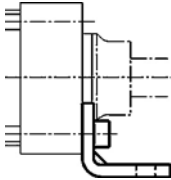
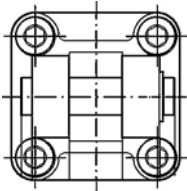
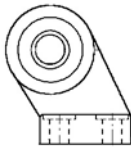
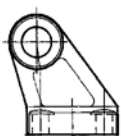
Bore size (mm)	F Rod/Head end flange	D Female head end clevis (Corresponds to E accessory)	C Male head end clevis	
				
	Supplied with 4 screws.	Supplied with bolt, safety device and 4 screws.	Supplied with 4 screws.	
			Plain	With ball joint
32	F5032	D5032	C5032	CS5032
40	F5040	D5040	C5040	CS5040
50	F5050	D5050	C5050	CS5050
63	F5063	D5063	C5063	CS6063
80	F5080	D5080	C5080	CS5080
100	F5100	D5100	C5100	CS5100
125	F5125	D5125	C5125	CS5125
	Page 24 for dimensions.	Page 24 and 25 for dimensions.	Page 24 and 25 for dimensions.	
Bore size (mm)	L Foot	DS Female head end clevis (for ES accessory)	ES Angled head end clevis with ball joint	E Angled head end clevis
				
	Supplied with 2 pieces and 4 screws.			
32	L5032	DS5032	ES5032	E5032
40	L5040	DS5040	ES5040	E5040
50	L5050	DS5050	ES5050	E5050
63	L5063	DS5063	ES5063	E5063
80	L5080	DS5080	ES5080	E5080
100	L5100	DS5100	ES5100	E5100
125	L5125	DS5125	ES5125	E5125
	Page 24 for dimensions.	Page 26 for dimensions.	Page 26 for dimensions.	Page 25 for dimensions.

Piston Rod Mounting Accessories

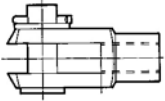
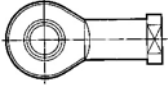
Bore size (mm)	GKM Rod clevis (ISO 8140)	KJ Piston rod ball joint (ISO 8139)	JA Floating joint
			
	Supplied with bolt and safety device.		
32	GKM10-20	KJ10D	JA30-10-125
40	GKM12-24	KJ12D	JA40-12-125
50	GKM16-32	KJ16D	JA50-16-150
63	GKM16-32	KJ16D	JA50-16-150
80	GKM20-40	KJ20D	JAH50-20-150
100	GKM20-40	KJ20D	JAH50-20-150
125	GKM30-54	KJ27D	JA125-27-200
	Page 27 for dimensions.	Page 27 for dimensions.	Page 27 for dimensions.

Series C96

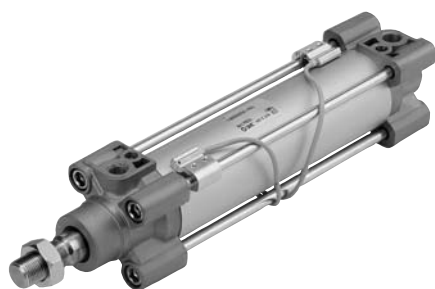

JIS Symbol
Double acting

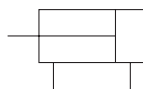

Minimum Stroke for Auto Switch Mounting

Refer to page 28 for "Minimum Stroke for Auto Switch Mounting".

Specifications

Bore size (mm)	32	40	50	63	80	100	125
Action	Double acting						
Fluid	Air						
Proof pressure	1.5 MPa						
Max. operating pressure	1.0 MPa						
Min. operating pressure	0.05 MPa						
Ambient and fluid temperature	Without auto switch: -20 to 70°C With auto switch: -10 to 60°C						
Lubrication	Not required (Non-lube)						
Operating piston speed	50 to 1000 mm/s						50 to 700 mm/s
Allowable stroke tolerance	Up to 250 st: $^{+1.0}_0$, 251 to 1000 st: $^{+1.4}_0$, 1001 to 1500 st: $^{+1.8}_0$, 1501 to 2000 st: $^{+2.2}_0$						
Cushion	Both ends (Air cushion)						
Port size	G 1/8	G 1/4	G 1/4	G 3/8	G 3/8	G 1/2	G 1/2
Mounting	Basic, Axial foot, Rod end flange, Head end flange, Single clevis, Double clevis, Center trunnion						

Standard Stroke

Bore size (mm)	Standard stroke (mm)	Max. * stroke
32	25, 50, 80, 100, 125, 160, 200, 250, 320, 400, 500	1000
40	25, 50, 80, 100, 125, 160, 200, 250, 320, 400, 500	1900
50	25, 50, 80, 100, 125, 160, 200, 250, 320, 400, 500, 600	1900
63	25, 50, 80, 100, 125, 160, 200, 250, 320, 400, 500, 600	1900
80	25, 50, 80, 100, 125, 160, 200, 250, 320, 400, 500, 600, 700, 800	1900
100	25, 50, 80, 100, 125, 160, 200, 250, 320, 400, 500, 600, 700, 800	1900
125	—	2000

Intermediate strokes are available.

* Please consult with SMC for longer strokes.

Accessories

Mounting		Basic	Foot	Rod end flange	Head end flange	Single clevis	Double clevis	Center trunnion
Standard	Rod end nut	●	●	●	●	●	●	●
	Clevis pin	—	—	—	—	—	●	—
Option	Piston rod ball joint	●	●	●	●	●	●	●
	Rod clevis	●	●	●	●	●	●	●
	Rod boot	●	●	●	●	●	●	●

* Please do not use a piston rod ball joint (or floating joint) together with a head end clevis with a ball joint (or angled head end clevis with a ball joint).

ISO Cylinder: Standard Double Acting, Single/Double Rod **Series C96**

Theoretical Output



Allowable Kinetic Energy

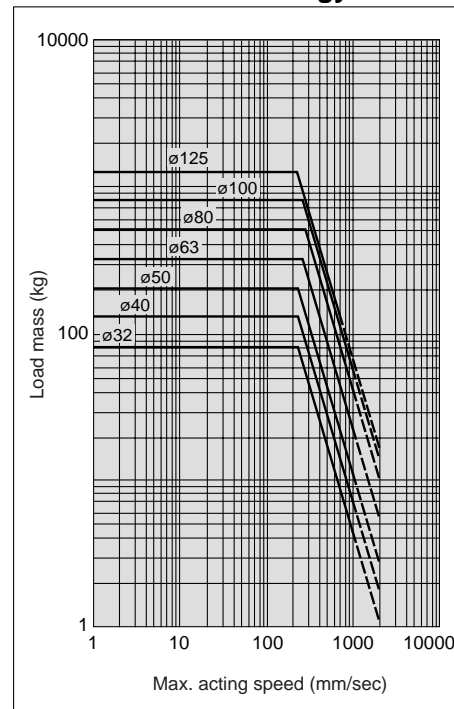

Example: Load limit at rod end when air cylinder ø63 is actuated with max. actuating speed 500 mm/s. See the intersection of lateral axis 500 mm/s and ø63 line, and extend the intersection to left. Thus, the allowable load is 80 kg.

Bore size (mm)	Rod diameter (mm)	Operating direction	Piston area (mm ²)	Operating pressure (MPa)								
				0.2	0.3	0.4	0.5	0.6	0.7	0.8	0.9	1.0
32	12	OUT	804	161	241	322	402	482	563	643	724	804
		IN	691	138	207	276	346	415	484	553	622	691
40	16	OUT	1257	251	377	503	629	754	880	1006	1131	1257
		IN	1056	211	317	422	528	634	739	845	950	1056
50	20	OUT	1963	393	589	785	982	1178	1374	1570	1767	1963
		IN	1649	330	495	660	825	989	1154	1319	1484	1649
63	20	OUT	3117	623	935	1247	1559	1870	2182	2494	2805	3117
		IN	2803	561	841	1121	1402	1682	1962	2242	2523	2803
80	25	OUT	5027	1005	1508	2011	2514	3016	3519	4022	4524	5027
		IN	4536	907	1361	1814	2268	2722	3175	3629	4082	4536
100	25	OUT	7854	1571	2356	3142	3927	4712	5498	6283	7068	7854
		IN	7363	1473	2209	2945	3682	4418	5154	5890	6627	7363
125	32	OUT	12272	2454	3682	4909	6136	7363	8590	9817	11045	12272
		IN	11468	2294	3440	4587	5734	6881	8027	9174	10321	11468

Note) Theoretical out put (N) = Pressure (MPa) x Piston area (mm²)

Mass

(kg)

Bore size (mm)		32	40	50	63	80	100	125
Basic mass	Basic	0.53	0.83	1.33	1.74	2.77	3.69	6.70
	Foot	0.16	0.20	0.38	0.46	0.89	1.09	2.60
	Flange	0.20	0.23	0.47	0.58	1.30	1.81	4.10
	Single clevis	0.16	0.23	0.37	0.60	1.07	1.73	4.15
	Double clevis	0.20	0.32	0.45	0.71	1.28	2.11	4.25
	Trunnion	0.71	1.10	1.73	2.48	4.25	5.95	2.98
Additional mass per each 50 mm stroke	All mounting brackets	0.11	0.16	0.24	0.26	0.40	0.44	0.71
Accessory	Single rod clevis	0.07	0.11	0.22		0.40		1.20
	Double rod clevis	0.09	0.15	0.34		0.69		1.84

Calculation: (Example) C96SD40-100

- Basic mass 0.83 (kg) (Basic, ø40)
 - Additional mass 0.16 (kg/50 st)
 - Cylinder stroke 100 (st)
 - Mounting 0.32 (kg) (Double clevis)
- 0.83 + 0.16 x 100 ÷ 50 + 0.32 = 1.47kg

Construction

[First angle projection]

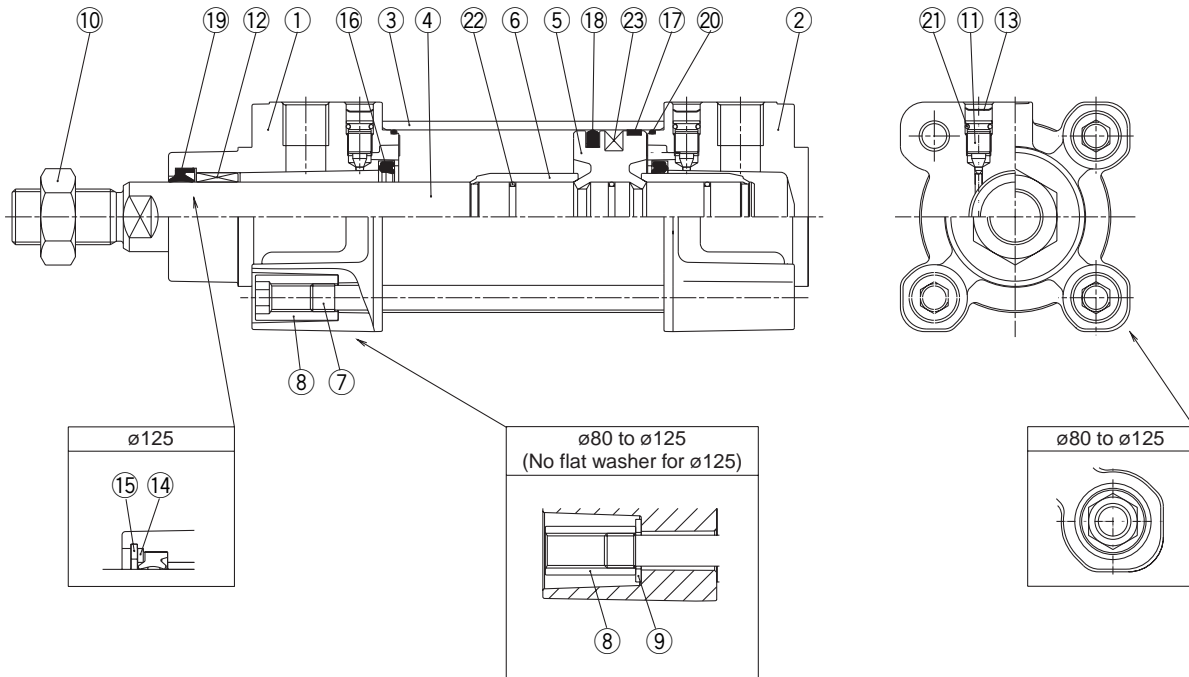

Component Parts

No.	Description	Material	Note
①	Rod cover	Aluminum die-casted	
②	Head cover	Aluminum die-casted	
③	Cylinder tube	Aluminum alloy	
④	Piston rod	Carbon steel	
⑤	Piston	Aluminum alloy	
⑥	Cushion ring	Brass	
⑦	Tie-rod	Carbon steel	
⑧	Tie-rod nut	Steel	
⑨	Flat washer	Steel	ø80 and ø100
⑩	Rod end nut	Steel	
⑪	Cushion valve	Steel wire	
⑫	Bushing	Sintered metal	
⑬	Snap ring	Steel for spring	ø40 to ø125
⑭	Rod seal holder	Stainless steel	ø125
⑮	Snap ring	Steel for spring	ø125
⑯	Cushion seal	Urethane rubber	
⑰	Wearing	Resin	
⑱	Piston seal	NBR	
⑲	Rod seal	NBR	
⑳	Cylinder tube gasket	NBR	
㉑	Cushion valve seal	NBR	
㉒	Piston gasket	NBR	
㉓	Magnet		

Replacement Parts: Seal Kit

Bore size (mm)	Kit no.	Contents
32	CS95-32	Kits include items ⑯ to ㉑.
40	CS95-40	
50	CS95-50	
63	CS95-63	
80	CS95-80	
100	CS96-100	
125	CS96-125	

* Seal kits consist of items ⑯ to ㉑ contained in one kit, and can be ordered using the number for each respective tube bore size.

Dimensions: Without Mounting Bracket

[First angle projection]

C96S(D)B Bore size Stroke

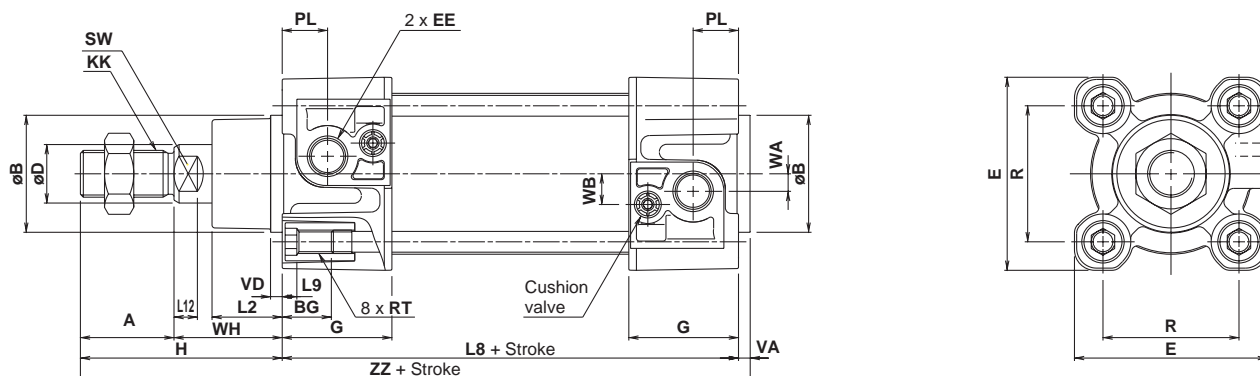

C96S(D)B Bore size Stroke

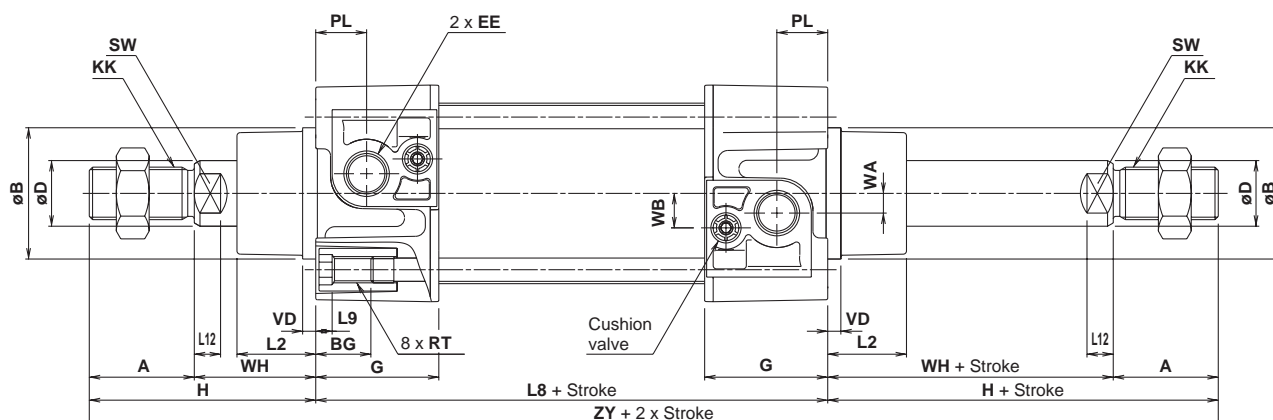

Bore size (mm)	A	ϕB d11	ϕD	EE	PL	RT	L12	KK	SW	G	BG	L8	VD	VA	WA	WB	WH	ZZ	ZY	E	R	L2	L9	H
32	22	30	12	G 1/8	13	M6 x 1	6	M10 x 1.25	10	32	16	94	4	4	4	7	26	146	190	47	32.5	15	4	48
40	24	35	16	G 1/4	14	M6 x 1	6.5	M12 x 1.25	13	37.5	16	105	4	4	5	9	30	163	213	54	38	17	4	54
50	32	40	20	G 1/4	15.5	M8 x 1.25	8	M16 x 1.5	17	37.5	16	106	4	4	6	10.5	37	179	244	66	46.5	24	5	69
63	32	45	20	G 3/8	16.5	M8 x 1.25	8	M16 x 1.5	17	45	16	121	4	4	9	12	37	194	259	77	56.5	24	5	69
80	40	45	25	G 3/8	19	M10 x 1.5	10	M20 x 1.5	22	45	17	128	4	4	11.5	14	46	218	300	99	72	30	—	86
100	40	55	25	G 1/2	19	M10 x 1.5	10	M20 x 1.5	22	50	17	138	4	4	17	15	51	233	320	118	89	32	—	91
125	54	60	32	G 1/2	19	M12 x 1.75	13	M27 x 2	27	58	20	160	6	6	17	15	65	285	398	144	110	40	—	119

Series C96

Dimensions: Cylinder Mounting Accessories

[First angle projection]

Foot (L)

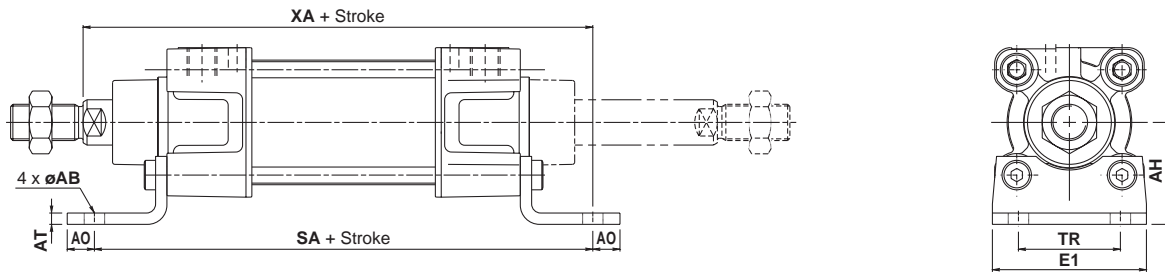

Center trunnion (T)

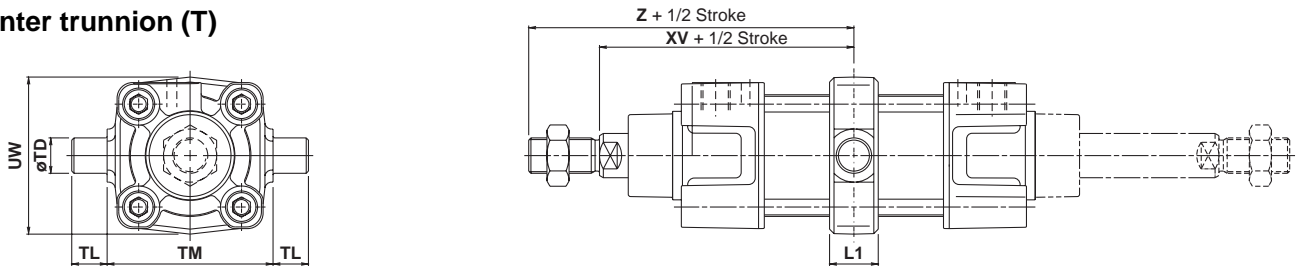

Flange (F/G)

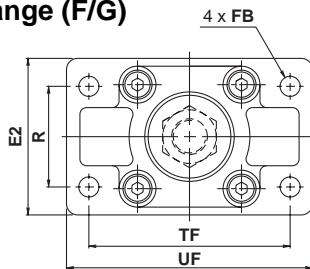

Head end mounting (G)

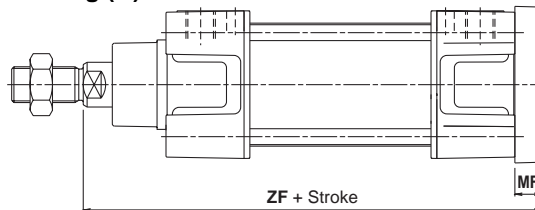

Rod end mounting (F)

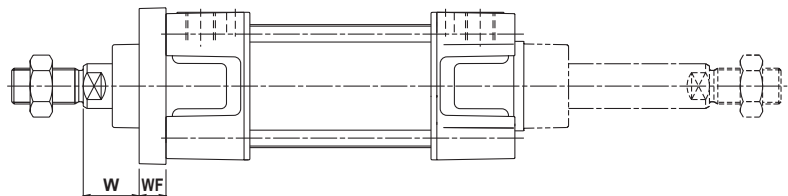

Head end single clevis (C)

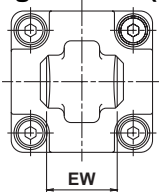

Head end double clevis (D)

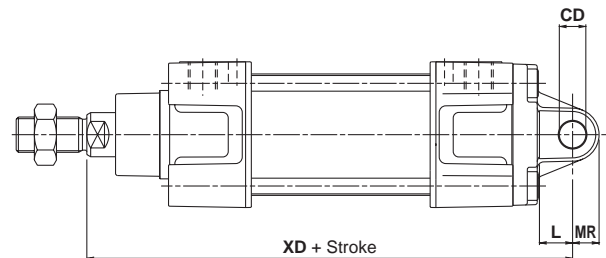
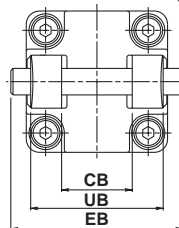

Bore size (mm)	E1	TR	AH	AO	AT	øAB	SA	XA	TM	TL	øTD e8	UW	L1	XV	Z	R	TF	øFB	E2	UF	W	MF	ZF	UB h14	CB H14	EW	øCD H9	L	MR	XD	EB
32	48	32	32	10	4.5	7	142	144	50	12	12	49	17	73	95	32	64	7	50	79	16	10	130	45	26	26-0.2/-0.6	10	12	9.5	142	65
40	55	36	36	11	4.5	10	161	163	63	16	16	58	22	82.5	106.5	36	72	9	55	90	20	10	145	52	28	28-0.2/-0.6	12	15	12	160	75
50	68	45	45	12	5.5	10	170	175	75	16	16	71	22	90	122	45	90	9	70	110	25	12	155	60	32	32-0.2/-0.6	12	15	12	170	80
63	80	50	50	12	5.5	10	185	190	90	20	20	87	28	97.5	129.5	50	100	9	80	120	25	12	170	70	40	40-0.2/-0.6	16	20	16	190	90
80	100	63	63	14	6.5	12	210	215	110	20	20	110	34	110	150	63	126	12	100	153	30	16	190	90	50	50-0.2/-0.6	16	20	16	210	110
100	120	75	71	16	6.5	14.5	220	230	132	25	25	136	40	120	160	75	150	14	120	178	35	16	205	110	60	60-0.2/-0.6	20	25	20	230	140
125	Max. 157	90	90	Max. 25	8	16	250	270	160	25	25	Max. 160	50	145	199	90	180	16	Max. 157	Max. 224	45	20	245	130	70	70-0.5/-1.2	25	Min. 30	Max. 26	275	Max. 157

Dimensions: Cylinder Mounting Accessories (C/D/E/CS)

[First angle projection]

Mounting (C)

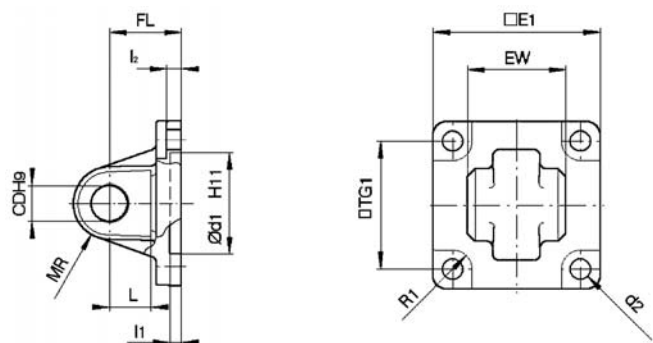

Mounting (D)

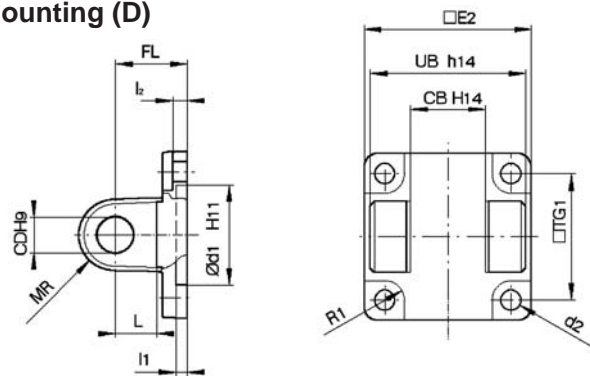

Bore size (mm)	E ₁	EW	TG ₁	FL	l ₁	L	l ₂	ød ₁	øCD	MR	ød ₂	R ₁	E ₂	UB	CB
32	45	26 ^{-0.2} _{-0.6}	32.5	22	5	12	5.5	30	10	9.5	6.6	6.5	48	45	26
40	51	28 ^{-0.2} _{-0.6}	38	25	5	15	5.5	35	12	12	6.6	6.5	56	52	28
50	64	32 ^{-0.2} _{-0.6}	46.5	27	5	15	6.5	40	12	12	9	8.5	64	60	32
63	74	40 ^{-0.2} _{-0.6}	56.5	32	5	20	6.5	45	16	16	9	8.5	75	70	40
80	94	50 ^{-0.2} _{-0.6}	72	36	5	20	10	45	16	16	11	11	95	90	50
100	113	60 ^{-0.2} _{-0.6}	89	41	5	25	10	55	20	20	11	12	115	110	60
125	Max. 157	70 ^{-0.5} _{-1.2}	110	50	7	30	10	60	25	26	13.5	10	Max. 157	130	70

Mounting (E)

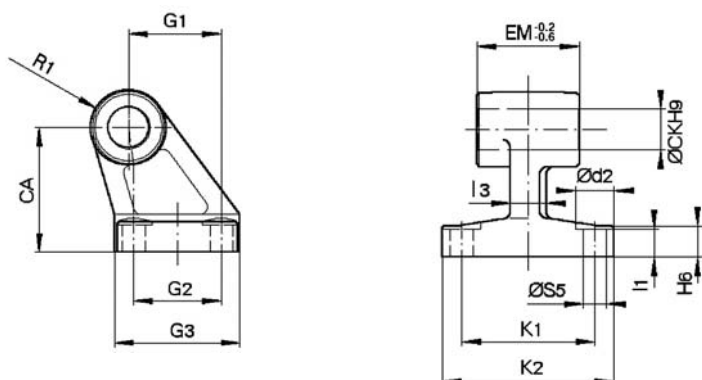

Bore size (mm)	ød ₂	øCK	øS5	K ₁	K ₂ max.	l ₃ max.	G ₁	l ₁	G ₂	EM	G ₃ max.	CA	H ₆	R ₁
32	11	10	6.6	38	51	10	21	7	18	26 ^{-0.2} _{-0.6}	31	32	8	10
40	11	12	6.6	41	54	10	24	9	22	28 ^{-0.2} _{-0.6}	35	36	10	11
50	15	12	9	50	65	12	33	11	30	32 ^{-0.2} _{-0.6}	45	45	12	12
63	15	16	9	52	67	14	37	11	35	40 ^{-0.2} _{-0.6}	50	50	12	15
80	18	16	11	66	86	18	47	12.5	40	50 ^{-0.2} _{-0.6}	60	63	14	15
100	18	20	11	76	96	20	55	13.5	50	60 ^{-0.2} _{-0.6}	70	71	15	19
125	20	25	14	94	124	30	70	17	60	70 ^{-0.5} _{-1.5}	90	90	20	22.5

Mounting (CS): Head end clevis with ball joint

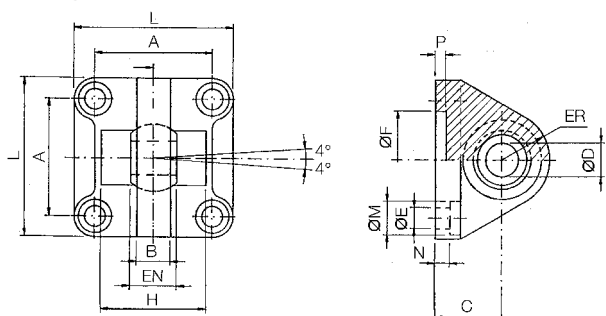

Bore size (mm)	A	B max.	C	øD H7	EN 0-0.1	ER max.	øF H11	øE	L	øM	N	P	H ±0.5
32	32.5	10.5	22	10	14	15	30	6.6	45	10.5	5.5	5	—
40	38	12	25	12	16	18	35	6.6	55	11	5.5	5	—
50	46.5	15	27	16	21	20	40	9	65	15	6.5	5	51
63	56.5	15	32	16	21	23	45	9	75	15	6.5	5	—
80	72	18	36	20	25	27	45	11	95	18	10	5	70
100	89	18	41	20	25	30	55	11	115	18	10	5	—
125	110	25	50	30	37	40	60	13.5	140	20	10	7	100

* Black color



Series C96

Dimensions: Cylinder Mounting Accessories (DS/ES)

[First angle projection]

Mounting (DS)

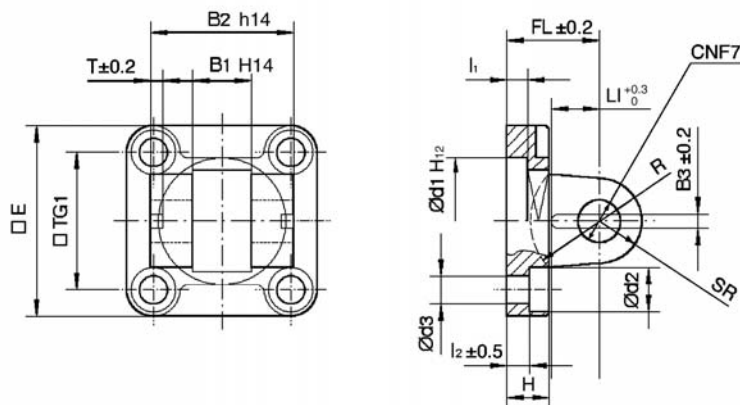

Bore size (mm)	E	B ₁	B ₂	B ₃	LI	TG ₁	T	I ₁ min.	I ₂	FL	H max.	Ød ₁	Ød ₂	Ød ₃	ØCN	SR max.	R
32	45	14	34	3.3	11.5	32.5	3	5	5.5	22	10	30	10.5	6.6	10	11	17
40	55	16	40	4.3	12	38	4	5	5.5	25	10	35	11	6.6	12	13	20
50	65	21	45	4.3	14	46.5	4	5	6.5	27	12	40	15	9	16	18	22
63	75	21	51	4.3	14	56.5	4	5	6.5	32	12	45	15	9	16	18	25
80	95	25	65	4.3	16	72	4	5	10	36	16	45	18	11	20	22	30
100	115	25	75	6.3	16	89	4	5	10	41	16	55	18	11	20	22	32
125	140	37	97	6.3	24	110	6	7	10	50	20	60	20	13.5	30	30	42

* Black color

Mounting (ES)

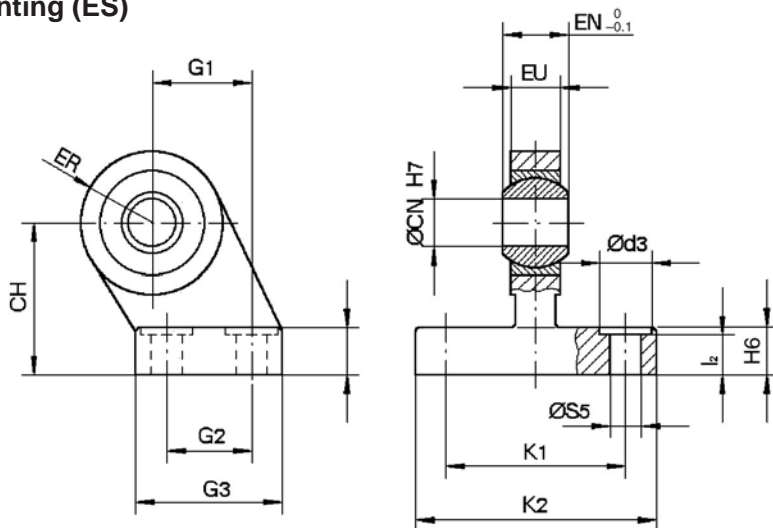

Bore size (mm)	Ød ₃	ØCN	ØS ₅	K ₁	K ₂ max.	l ₂	G ₁	G ₂	G ₃ max.	EN	EU	CH	H ₆	ER max.
32	11	10	6.6	38	51	8.5	21	18	31	14	10.5	32	10	15
40	11	12	6.6	41	54	8.5	24	22	35	16	12	36	10	18
50	15	16	9	50	65	10.5	33	30	45	21	15	45	12	20
63	15	16	9	52	67	10.5	37	35	50	21	15	50	12	23
80	18	20	11	66	86	11.5	47	40	60	25	18	63	14	27
100	18	20	11	76	96	12.5	55	50	70	25	18	71	15	30
125	20	30	13.5	94	124	17	70	60	90	37	25	90	20	40

* Black color

Dimensions: Piston Rod Mounting Accessories

[First angle projection]

Floating Joint JA

Bore size (mm)	M	Part no.	A	B	C	∅D	E	F	G	H	P	U	Load (kN)	Mass (g)	Angle
32	M10 x 1.25	JA30-10-125	49.5	19.5	—	24	5	8	8	17	9	0.5	2.5	70	±0.5°
40	M12 x 1.25	JA40-12-125	60	20	—	31	6	11	11	22	13	0.75	4.4	160	
50, 63	M16 x 1.5	JA50-16-150	71.5	22	—	41	7.5	14	13.5	27	15	1	11	300	
80, 100	M20 x 1.5	JAH50-20-150	101	28	31	59.5	11.5	24	16	32	18	2	18	1080	
125	M27 x 2	JA125-27-200	123	34	38	66	13	27	20	41	24	2	28	1500	

* Black color

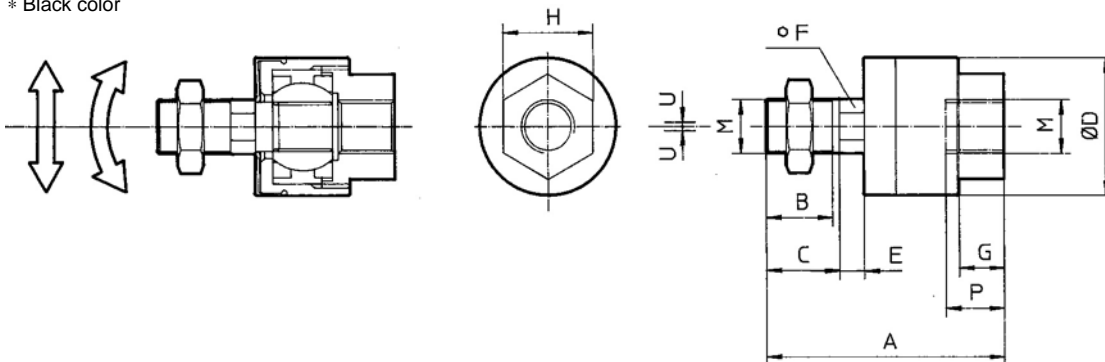

Rod Clevis GKM (ISO 8140), Supplied with Bolt and Safety Device

Bore size (mm)	e	Part no.	b	d	∅f h11 (Shaft)	∅f H9 (Hole)	l1	c min.	a max.
32	M10 x 1.25	GKM10-20	10 ^{+0.5} / _{+0.15}	40	10	10	52	20	20
40	M12 x 1.25	GKM12-24	12 ^{+0.5} / _{+0.15}	48	12	12	62	24	24
50, 63	M16 x 1.5	GKM16-32	16 ^{+0.5} / _{+0.15}	64	16	16	83	32	32
80, 100	M20 x 1.5	GKM20-40	20 ^{+0.5} / _{+0.15}	80	20	20	105	40	40
125	M27 x 2	GKM30-54	30 ^{+0.5} / _{+0.15}	110	30	30	148	54	55

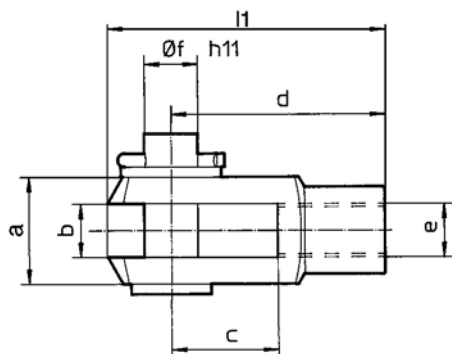

Piston Rod Ball Joint KJ (ISO 8139)

Bore size (mm)	d3	Part no.	∅d1 H9	h	d6 max.	b1 h12	l min.	a	l3
32	M10 x 1.25	KJ10D	10	43	28	14	20	4°	15
40	M12 x 1.25	KJ12D	12	50	32	16	22	4°	17
50, 63	M16 x 1.5	KJ16D	16	64	42	21	28	4°	23
80, 100	M20 x 1.5	KJ20D	20	77	50	25	33	4°	27
125	M27 x 2	KJ27D	30	110	70	37	51	4°	36

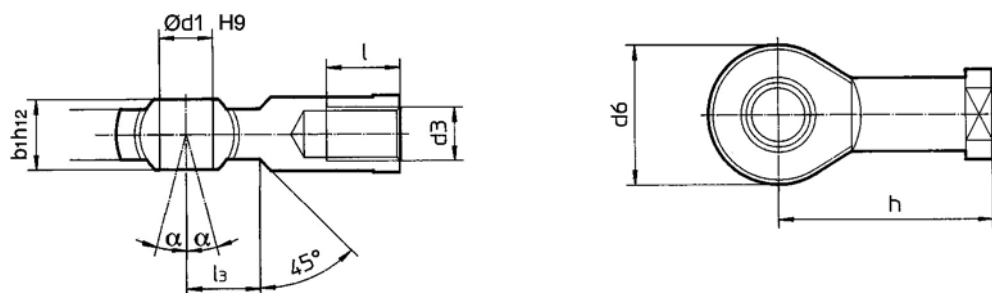

Minimum Stroke for Auto Switch Mounting

(mm)

Auto switch model	Number of auto switch mounted	Center trunnion						Support bracket other than Center trunnion			
		ø32	ø40	ø50	ø63	ø80	ø100	ø125	ø32, ø40, ø50, ø63	ø80, ø100	ø125
D-A9□	1 switch, 2 switches (Different side, Same side)	70	75		80	85	95	100	15		
	Other qty.	70 + 40 (n - 4)/2 n = 4, 8, 12, 16...	75 + 40 (n - 4)/2 n = 4, 8, 12, 16...		80 + 40 (n - 4)/2 n = 4, 8, 12, 16...	85 + 40 (n - 4)/2 n = 4, 8, 12, 16...	95 + 40 (n - 4)/2 n = 4, 8, 12, 16...	100 + 40 (n - 4)/2 n = 4, 8, 12, 16...	15 + 40 (n - 2)/2 n = 2, 4, 6, 8...		
D-A9□V	1 switch, 2 switches (Different side, Same side)	45	50		55	60	70	75	10		
	Other qty.	45 + 30 (n - 4)/2 n = 4, 8, 12, 16...	50 + 30 (n - 4)/2 n = 4, 8, 12, 16...		55 + 30 (n - 4)/2 n = 4, 8, 12, 16...	60 + 30 (n - 4)/2 n = 4, 8, 12, 16...	70 + 30 (n - 4)/2 n = 4, 8, 12, 16...	75 + 30 (n - 4)/2 n = 4, 8, 12, 16...	10 + 30 (n - 2)/2 n = 2, 4, 6, 8...		
D-M9□ D-M9□W	1 switch, 2 switches (Different side, Same side)	75	80		85	90	95	105	15		
	Other qty.	75 + 40 (n - 4)/2 n = 4, 8, 12, 16...	80 + 40 (n - 4)/2 n = 4, 8, 12, 16...		85 + 40 (n - 4)/2 n = 4, 8, 12, 16...	90 + 40 (n - 4)/2 n = 4, 8, 12, 16...	95 + 40 (n - 4)/2 n = 4, 8, 12, 16...	105 + 40 (n - 4)/2 n = 4, 8, 12, 16...	15 + 40 (n - 2)/2 n = 2, 4, 6, 8...		
D-M9□V D-M9□WV	1 switch, 2 switches (Different side, Same side)	50	55		60	65	70	80	10		
	Other qty.	50 + 30 (n - 4)/2 n = 4, 8, 12, 16...	55 + 30 (n - 4)/2 n = 4, 8, 12, 16...		60 + 30 (n - 4)/2 n = 4, 8, 12, 16...	65 + 30 (n - 4)/2 n = 4, 8, 12, 16...	70 + 30 (n - 4)/2 n = 4, 8, 12, 16...	80 + 30 (n - 4)/2 n = 4, 8, 12, 16...	10 + 30 (n - 2)/2 n = 2, 4, 6, 8...		
D-M9□AL	1 switch, 2 switches (Different side, Same side)	80	85		90	95	100	110	15		
	Other qty.	80 + 40 (n - 2)/2 n = 4, 8, 12, 16...	85 + 40 (n - 2)/2 n = 4, 8, 12, 16...		90 + 40 (n - 2)/2 n = 4, 8, 12, 16...	95 + 40 (n - 2)/2 n = 4, 8, 12, 16...	100 + 40 (n - 2)/2 n = 4, 8, 12, 16...	110 + 40 (n - 2)/2 n = 4, 8, 12, 16...	15 + 40 (n - 2)/2 n = 2, 4, 6, 8...		
D-M9□AVL	1 switch, 2 switches (Different side, Same side)	55	60		65	70	75	85	15		
	Other qty.	55 + 30 (n - 2)/2 n = 4, 8, 12, 16...	60 + 30 (n - 2)/2 n = 4, 8, 12, 16...		65 + 30 (n - 2)/2 n = 4, 8, 12, 16...	70 + 30 (n - 2)/2 n = 4, 8, 12, 16...	75 + 30 (n - 2)/2 n = 4, 8, 12, 16...	85 + 30 (n - 2)/2 n = 4, 8, 12, 16...	15 + 30 (n - 2)/2 n = 2, 4, 6, 8...		
D-A3□ D-G39 D-K39	2 switches (Different side)	60	65		75	80	85	90	35		
	2 switches (Same side)	90	95		100	105	110	125	100		
	Other qty. (Different side)	60 + 30 (n - 2) n = 2, 4, 6, 8...	65 + 30 (n - 2) n = 2, 4, 6, 8...		75 + 30 (n - 2) n = 2, 4, 6, 8...	80 + 30 (n - 2) n = 2, 4, 6, 8...	85 + 30 (n - 2) n = 2, 4, 6, 8...	90 + 30 (n - 2) n = 2, 4, 6, 8...	35 + 30 (n - 2) n = 2, 3, 4...		
	Other qty. (Same side)	90 + 100 (n - 2) n = 2, 4, 6, 8...	95 + 100 (n - 2) n = 2, 4, 6, 8...		100 + 100 (n - 2) n = 2, 4, 6, 8...	105 + 100 (n - 2) n = 2, 4, 6, 8...	110 + 100 (n - 2) n = 2, 4, 6, 8...	125 + 100 (n - 2) n = 2, 4, 6, 8...	100 + 100 (n - 2) n = 2, 3, 4...		
D-A44	1 switch	60	65		75	80	85	90	10		
	2 switches (Different side)	70	75		80		85	90	35		
	2 switches (Same side)	70	75		80		85	90	55		
	Other qty. (Different side)	70 + 30 (n - 2) n = 2, 4, 6, 8...	75 + 30 (n - 2) n = 2, 4, 6, 8...		80 + 30 (n - 2) n = 2, 4, 6, 8...		85 + 30 (n - 2) n = 2, 4, 6, 8...	90 + 30 (n - 2) n = 2, 4, 6, 8...	35 + 30 (n - 2) n = 2, 3, 4...		
	Other qty. (Same side)	70 + 50 (n - 2) n = 2, 4, 6, 8...	75 + 50 (n - 2) n = 2, 4, 6, 8...		80 + 50 (n - 2) n = 2, 4, 6, 8...		85 + 50 (n - 2) n = 2, 4, 6, 8...	90 + 50 (n - 2) n = 2, 4, 6, 8...	55 + 50 (n - 2) n = 2, 3, 4...		
D-A5□ D-A6□	1 switch, 2 switches (Different side, Same side)	60		80	105	110	115		15	20	
	Other qty. (Same side)	60 + 55 (n - 4)/2 n = 4, 8, 12, 16...		80 + 55 (n - 4)/2 n = 4, 8, 12, 16...	105 + 55 (n - 4)/2 n = 4, 8, 12, 16...	110 + 55 (n - 4)/2 n = 4, 8, 12, 16...	115 + 55 (n - 4)/2 n = 4, 8, 12, 16...		15 + 55 (n - 2)/2 n = 2, 4, 6, 8...	20 + 55 (n - 2)/2 n = 2, 4, 6, 8...	
D-A59W	2 switches (Different side, Same side)	60	70	85	110	115	120		20	25	
	Other qty. (Same side)	60 + 55 (n - 4)/2 n = 4, 8, 12, 16...	70 + 55 (n - 4)/2 n = 4, 8, 12, 16...	85 + 55 (n - 4)/2 n = 4, 8, 12, 16...	110 + 55 (n - 4)/2 n = 4, 8, 12, 16...	115 + 55 (n - 4)/2 n = 4, 8, 12, 16...	120 + 55 (n - 4)/2 n = 4, 8, 12, 16...		20 + 55 (n - 2)/2 n = 2, 4, 6, 8...	25 + 55 (n - 2)/2 n = 2, 4, 6, 8...	
	1 switch	60	70	85	110	115	120		15	25	
D-F5□ D-J5□ D-F5□W D-J59W D-F5BAL D-F59F	2 switches (Different side, Same side)	90	95		110	115	120	130	15	25	
	Other qty. (Same side)	90 + 55 (n - 4)/2 n = 4, 8, 12, 16...	95 + 55 (n - 4)/2 n = 4, 8, 12, 16...		110 + 55 (n - 4)/2 n = 4, 8, 12, 16...	115 + 55 (n - 4)/2 n = 4, 8, 12, 16...	120 + 55 (n - 4)/2 n = 4, 8, 12, 16...	130 + 55 (n - 4)/2 n = 4, 8, 12, 16...	15 + 55 (n - 2)/2 n = 2, 4, 6, 8...	25 + 55 (n - 2)/2 n = 2, 4, 6, 8...	
	1 switch	90	95		110	115	120	130	10	25	
	2 switches (Different side, Same side)	100	105		120	125	130	140	15	25	30
D-F5NTL	Other qty. (Same side)	100 + 55 (n - 4)/2 n = 4, 8, 12, 16...	105 + 55 (n - 4)/2 n = 4, 8, 12, 16...		120 + 55 (n - 4)/2 n = 4, 8, 12, 16...	125 + 55 (n - 4)/2 n = 4, 8, 12, 16...	130 + 55 (n - 4)/2 n = 4, 8, 12, 16...	140 + 55 (n - 4)/2 n = 4, 8, 12, 16...	15 + 55 (n - 2)/2 n = 2, 4, 6, 8...	25 + 55 (n - 2)/2 n = 2, 4, 6, 8...	30 + 55 (n - 2)/2 n = 2, 4, 6, 8...
	1 switch	100	105		120	125	130	140	10	25	30
	2 switches (Different side, Same side)	80	85	90		95	100	105	15		
D-Z7□ D-Z80 D-Y59□ D-Y7P D-Y7□W	1 switch, 2 switches (Different side, Same side)	80	85	90		95	100	105	15		
	Other qty.	80 + 40 (n - 4)/2 n = 4, 8, 12, 16...	85 + 40 (n - 4)/2 n = 4, 8, 12, 16...	90 + 40 (n - 4)/2 n = 4, 8, 12, 16...		95 + 40 (n - 4)/2 n = 4, 8, 12, 16...	100 + 40 (n - 4)/2 n = 4, 8, 12, 16...	105 + 40 (n - 4)/2 n = 4, 8, 12, 16...	15 + 40 (n - 2)/2 n = 2, 4, 6, 8...		
D-Y69□ D-Y7PV D-Y7□WV	1 switch, 2 switches (Different side, Same side)	60	65		70	75	85		10		
	Other qty.	60 + 30 (n - 4)/2 n = 4, 8, 12, 16...	65 + 30 (n - 4)/2 n = 4, 8, 12, 16...		70 + 30 (n - 4)/2 n = 4, 8, 12, 16...	75 + 30 (n - 4)/2 n = 4, 8, 12, 16...	85 + 30 (n - 4)/2 n = 4, 8, 12, 16...		10 + 30 (n - 2)/2 n = 2, 4, 6, 8...		
D-Y7BAL	1 switch, 2 switches (Different side, Same side)	85	90		100	105	110	115	20		
	Other qty.	85 + 45 (n - 4)/2 n = 4, 8, 12, 16...	90 + 45 (n - 4)/2 n = 4, 8, 12, 16...		100 + 45 (n - 4)/2 n = 4, 8, 12, 16...	105 + 45 (n - 4)/2 n = 4, 8, 12, 16...	110 + 45 (n - 4)/2 n = 4, 8, 12, 16...	115 + 45 (n - 4)/2 n = 4, 8, 12, 16...	20 + 45 (n - 2)/2 n = 2, 4, 6, 8...		
D-P4DWL	1 switch, 2 switches (Different side, Same side)	120		130		140		150	15		20
	Other qty.	120 + 65 (n - 4)/2 n = 4, 8, 12, 16...		130 + 65 (n - 4)/2 n = 4, 8, 12, 16...		140 + 65 (n - 4)/2 n = 4, 8, 12, 16...		150 + 65 (n - 4)/2 n = 4, 8, 12, 16...	15 + 65 (n - 2)/2 n = 2, 4, 6, 8...		20 + 65 (n - 2)/2 n = 2, 4, 6, 8...

Auto Switch Proper Mounting Position (Detection at Stroke End) and Its Mounting Height [First angle projection]

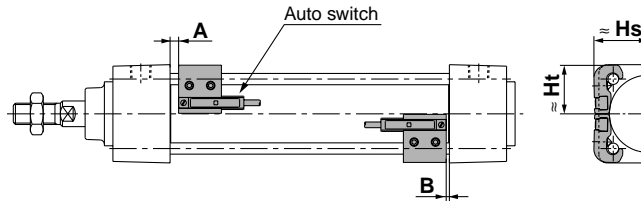

Auto Switch Proper Mounting Position

(mm)

Auto switch model	D-A9□ D-A9□V		D-M9□ D-M9□V D-M9□W D-M9□WV D-M9□AL D-M9□AVL		D-A5□ D-A6□		D-A59W		D-F5□W D-J59W D-F5□ D-J5□ D-F5BAL D-F59F		D-F5NTL		D-A3□ D-A44 D-G39 D-K39		D-Z7□ D-Z80 D-Y59□ D-Y69□ D-Y7P D-Y7PV D-Y7□W D-Y7□WV D-Y7BAL		D-P4DWL		
	A	B	A	B	A	B	A	B	A	B	A	B	A	B	A	B	A	B	
Bore size																			
32	6.5	4	10.5	8	0.5	0	4.5	2	7	4.5	12	9.5	0.5	0	4	1.5	3.5	1	
40	6.5	4	10.5	8	0.5	0	4.5	2	7	4.5	12	9.5	0.5	0	4	1.5	3.5	1	
50	7	4.5	11	8.5	1	0	5	2.5	7.5	5	12.5	10	1	0	4.5	2	4	1.5	
63	7	4.5	11	8.5	1	0	5	2.5	7.5	5	12.5	10	1	0	4.5	2	4	1.5	
80	10	8.5	14	12.5	4	2.5	8	6.5	10.5	9	15.5	14	4	2.5	7.5	6	7	5.5	
100	10	8.5	14	12.5	4	2.5	8	6.5	10.5	9	15.5	14	4	2.5	7.5	6	7	5.5	
125	12	12	16	16	6	6	10	10	12.5	12.5	17.5	17.5	6	6	9.5	9.5	9	9	

Note) Adjust the auto switch after confirming the operation to set actually.

Auto Switch Proper Mounting Height

(mm)

Auto switch model	D-A9□ D-M9□ D-M9□W D-M9□AL		D-A9□V		D-M9□V D-M9□WV D-M9□AVL		D-A5□ D-A6□ D-A59W		D-F5□ D-J5□ D-F59F D-F5□W D-J59W D-F5BAL D-F5NTL		D-A3□ D-G39 D-K39		D-A44		D-Z7□ D-Z80 D-Y59□ D-Y7P D-Y7PV D-Y7□W D-Y7BAL		D-Y69□ D-Y7PV D-Y7□WV		D-P4DWL		
	Hs	Ht	Hs	Ht	Hs	Ht	Hs	Ht	Hs	Ht	Hs	Ht	Hs	Ht	Hs	Ht	Hs	Ht	Hs	Ht	
Bore size																					
32	24.5	23	27.5	23	30.5	23	35	24.5	32.5	25	67	27.5	77	27.5	25.5	23	26.5	23	38	31	
40	28.5	25.5	31.5	25.5	34	25.5	38.5	27.5	36.5	27.5	71.5	27.5	81.5	27.5	29.5	26	30	26	42	33	
50	33.5	31	36	31	38.5	31	43.5	34.5	41	34	77	—	87	—	33.5	31	34.5	31	46.5	39	
63	38.5	36	40.5	36	43	36	48.5	39.5	46	39	83.5	—	93.5	—	39	36	40	36	51.5	44	
80	46.5	45	49	45	52	45	55	46.5	52.5	46.5	92.5	—	103	—	47.5	45	48.5	45	58	51.5	
100	54	53.5	57	53.5	59.5	53.5	62	55	59.5	55	103	—	113.5	—	55.5	53.5	56.5	53.5	65.5	60.5	
125	65.5	64.5	68.5	64.5	71	64.5	71.5	66.5	70.5	66.5	115	—	125	—	67.5	65	68.5	65	76.5	72	

Series C96

Auto Switch Mounting Bracket Part No.

Auto switch model	Bore size (mm)						
	ø32	ø40	ø50	ø63	ø80	ø100	ø125
D-A9□/A9□V D-M9□/M9□V D-M9□W/M9□WV D-M9□AL/M9□AVL	BMB5-032	BMB5-032	BA7-040	BA7-040	BA7-063	BA7-063	BA7-080
D-A3□/A44 D-G39/K39	BMB2-032	BMB2-040	BMB1-050	BMB1-063	BMB1-080	BMB1-100	BS1-125
D-A5□/A6□ D-A59W D-F5□/J5□ D-F5□W/J59W D-F59F D-F5BAL D-F5NTL	BT-03	BT-03	BT-05	BT-05	BT-06	BT-06	BT-08
D-P4DWL	BMB3T-040	BMB3T-040	BMB3T-050	BMB3T-050	BMB3T-080	BMB3T-080	BAP2T-080
D-Z7□/Z80 D-Y59□/Y69□ D-Y7P/Y7PV D-Y7□W D-Y7□WV D-Y7BAL	BMB4-032	BMB4-032	BMB4-050	BMB4-050	BA4-063	BA4-063	BA4-080

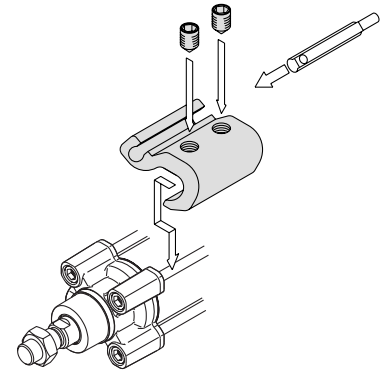

• Mounting example for D-A9□(V), M9□(V), M9□W(V), M9□A(V)L

[Mounting screws set made of stainless steel]

The following set of mounting screws made of stainless steel is also available. Use it in accordance with the operating environment. (Please order the mounting bracket separately, since it is not included.)

BBA1: For D-A5/A6/F5/J5

Note 1) For details on BBA1, refer to page 34.

"D-F5BAL" switch is set on the cylinder with the stainless steel screws above when shipped from factory.

When a switch is shipped independently, "BBA1" screws are attached.

Note 2) When using type D-M9□A(V)L or Y7BAL, please do not use the iron set screws included with the auto switch mounting bracket (BMB5-032, BA7-□□□, BAB4-□□□, BA4-□□□) shown above, instead order the set of stainless steel set screws (BBA1), and please use the stainless steel set screws (M4 x 6L) included in BBA1.

Operating Range

Auto switch model	Bore size (mm)						
	32	40	50	63	80	100	125
D-A9□/A9□V	7	7.5	8.5	9.5	9.5	10.5	12
D-M9□/M9□V D-M9□W/M9□WV D-M9□AL/M9□AVL	4	4.5	5	6	6	6	7.5
D-Z7□/Z80	7.5	8.5	7.5	9.5	9.5	10.5	13
D-A5□/A6□	9	9	10	11	11	11	10
D-A59W	13	13	13	14	14	15	17
D-A3□/A44	9	9	10	11	11	11	10
D-Y59□/Y69□ D-Y7P/Y7□V D-Y7□W/Y7□WV D-Y7BAL	5.5	5.5	7	7.5	6.5	5.5	7
D-F5□/J5□ D-F5□W/J59W D-F5BAL/F5NTL D-F59F	3.5	4	4	4.5	4.5	4.5	5
D-G39/K39	9	9	9	10	10	11	11
D-P4DWL	4	4	4	4.5	4	4.5	4.5

* Since this is a guideline including hysteresis, not meant to be guaranteed. (Assuming approximately ±30% dispersion.) There may be the case it will vary substantially depending on an ambient environment.

Besides the models listed “How to Order,” the following auto switches are applicable.
For detailed auto switch specifications, refer to SMC “Best Pneumatics 2004” catalogs.

Type	Auto switch model	Electrical entry	Features
Solid state switch	**D-M9NV, M9PV, M9BV	Grommet (Perpendicular)	—
	D-Y69A, Y69B, Y7PV		Diagnosis indication (2-color)
	D-M9NWV, M9PWV, M9BWV		
	D-Y7NWV, Y7PWV, Y7BWV		
	D-M9NAVL, M9PAVL, M9BAVL		Water resistant (2-color)
	D-Y59A, Y59B, Y7P	Grommet (In-line)	—
	D-F59, F5P, J59		Diagnosis indication (2-color)
	D-Y7NW, Y7PW, Y7BW		
	D-F59W, F5PW, J59W		
	D-F5BAL, Y7BAL		Water resistant (2-color)
	D-F5NTL		With timer
	D-P5DWL		Strong magnetic field resistant (2-color)
	Reed switch	D-A93V, A96V	Grommet (Perpendicular)
D-A90V		Grommet (In-line)	Without indicator light
D-A67, Z80			
D-A53, A56, Z73, Z76			—

* For details about auto switches with pre-wired connector, refer to SMC “Best Pneumatics 2004” Vol.6 catalog.

* Normally closed (NC = b contact), solid state switch (D-F9G, F9H, Y7G, Y7H type) are also available.

For details, refer to SMC “Best Pneumatics 2004” Vol.7/8/9/10 catalog.

** D-M9BVM, M9NVM, M9PVM type (product of 1 m in length of the lead wire) are applicable from the shipment in May, 2008.

Specific Product Precautions

Adjustment

Warning

1. Do not open the cushion valve above the stopper.

Cushion valves are provided with a crimp ($\phi 32$) or a retaining ring ($\phi 40$ to $\phi 125$) as a stopping mechanism, and the cushion valve should not be opened above that point.

If air is supplied and operation started without confirming the above condition, the cushion valve may be ejected from the cover.

2. Be certain to activate the air cushion at the stroke end.

When it is intended to use the cushion valve in the fully opened position, select a style with a damper. If this is not done, the tie-rods or piston rod assembly will be damaged.

3. When replacing brackets, use the hexagon wrenches shown below.

Bore size (mm)	Width across flats	Tightening torque (N·m)
32, 40	4	5.1
50, 63	5	11
80, 100	6	19.2
125	10	30.1

Series C96

How to Mount and Move the Auto Switch

Mounting Bracket Tie-rod Mounting

<Applicable Auto Switch>

Solid state switch ... D-G39, D-K39

Reed switch D-A33, D-A34, D-A44

How to Mount and Move the Auto Switch

D-A3□, D-G3/K3 type

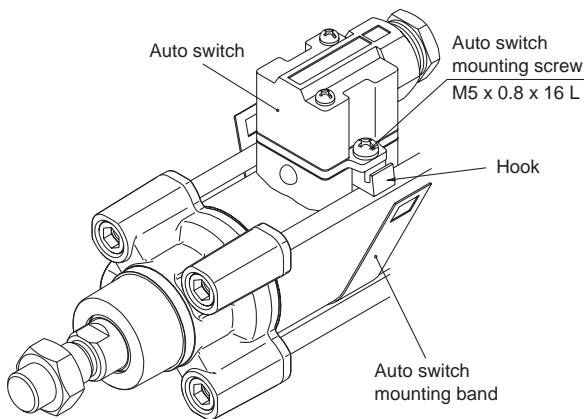

D-A44 type

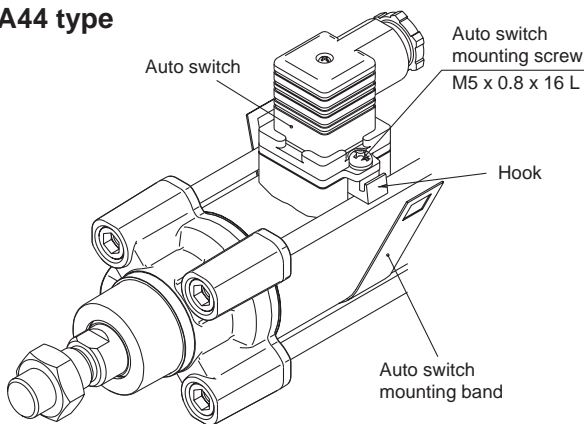

1. Loosen the auto switch mounting screws at both sides to pull down the hook.
2. Put an auto switch mounting band on the cylinder tube and set it at the auto switch mounting position, and then hook the band.
3. Screw lightly the auto switch mounting screw.
4. Set the whole body to the detecting position by sliding, tighten the mounting screw to secure the auto switch. (The tightening torque should be about 2 to 3 N·m.)
5. Modification of the detecting position should be made in the state of 3.

Auto Switch Mounting Bracket Part No. (Band)

Cylinder series	Applicable bore size (mm)						
	32	40	50	63	80	100	125
C96	BMB2-032	BMB2-040	BMB1-050	BMB1-063	BMB1-080	BMB1-100	BS1-125

<Applicable Auto Switch>

Solid state switch ... D-M9N(V), D-M9P(V), D-M9B(V)

D-M9NW(V), D-M9PW(V), D-M9BW(V)
D-M9NA(V), D-M9PA(V), D-M9BA(V)

Reed switch D-A90(V), A93(V), A96(V)

How to Mount and Move the Auto Switch

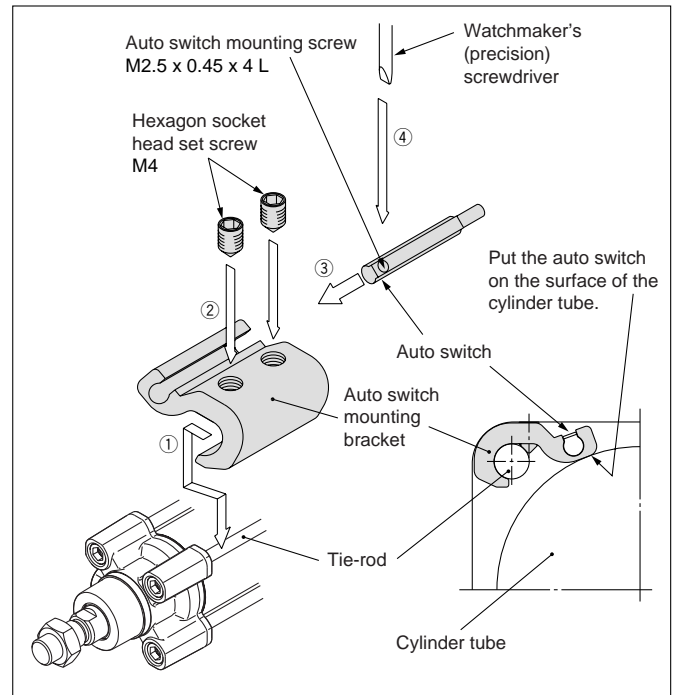

1. Fix it to the detecting position with a set screw by installing an auto switch mounting bracket in cylinder tie-rod and letting the bottom surface of an auto switch mounting bracket contact the cylinder tube firmly.
2. Fix it to the detecting position with a set screw (M4). (Use a hexagon wrench.)
3. Fit an auto switch into the auto switch mounting groove to set it roughly to the mounting position for an auto switch.
4. After confirming the detecting position, tighten up the mounting screw (M2.5) attached to an auto switch, and secure the auto switch.
5. When changing the detecting position, carry out in the state of 3.

Note 1) To protect auto switches, ensure that main body of an auto switch should be embedded into auto switch mounting groove with a depth of 15 mm or more.

Note 2) Set the tightening torque of a hexagon socket head set screw (M4) to be 1.0 to 1.2 N·m.

Note 3) When tightening an auto switch mounting screw (M2.5), use a watchmaker's screwdriver with a grip diameter of 5 to 6 mm.

Also, set the tightening torque to be 0.05 to 0.15 N·m. As a guide, turn 90° from the position where it comes to feel tight.

Auto Switch Mounting Bracket Part No. (Including Bracket, Set Screw)

Cylinder series	Applicable bore size (mm)						
	32	40	50	63	80	100	125
C96	BMB5-032	BMB5-040	BA7-040	BA7-040	BA7-063	BA7-063	BA7-080

Note 1) When using type D-M9□(A)(V)L, please order stainless steel screw set BBA1 separately (page 34), and use the stainless steel set screws—as shown in the table above.

Note 2) Color or gloss differences in the metal surfaces have no effect on metal performance.

The special properties of the chromate (trivalent) applied to the main body of the auto switch mounting bracket for BA7-□ and BMB5-□ result in differences in coloration depending on the production lot, but these have no adverse impact on corrosion resistance.

How to Mount and Move the Auto Switch

<Applicable Auto Switch>

Solid state switch ... D-Y59^A, Y69^A, D-Y7P(V)
D-Y7NW(V), Y7PW(V), Y7BW(V)
D-Y7BAL

Reed switch D-Z73, Z76, Z80

How to Mount and Move the Auto Switch

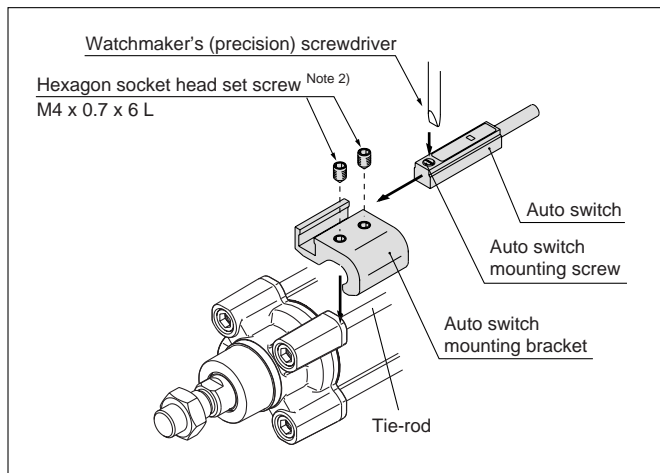

Note 1) When tightening an auto switch mounting screw, use a watchmaker's screwdriver with a handle diameter of 5 to 6 mm. Also, set the tightening torque to be 0.05 to 0.1 N·m. As a guide, turn 90° from the position where it comes to feel tight. Set the tightening torque of a hexagon socket head set screw (M4 x 0.7) to be 1.0 to 1.2 N·m.

1. Fix it to the detecting position with a set screw by installing an auto switch mounting bracket in cylinder tie-rod and letting the bottom surface of an auto switch mounting bracket contact the cylinder tube firmly. (Use a hexagon wrench.)
2. Fit an auto switch into the auto switch mounting groove to set it roughly to the mounting position for an auto switch.
3. After confirming the detecting position, tighten up the mounting screw attached to an auto switch, and secure the auto switch.
4. When changing the detecting position, carry out in the state of 2.

* To protect auto switches, ensure that main body of an auto switch should be embedded into auto switch mounting groove with a depth of 15 mm or more.

Auto Switch Mounting Bracket Part No. (Including Bracket, Set Screw)

Cylinder series	Applicable bore size (mm)						
	32	40	50	63	80	100	125
C96	BMB4-032	BMB4-032	BMB4-050	BMB4-050	BA4-063	BA4-063	BA4-080

Note 2) When using type D-Y7BAL, please order stainless steel screw set BBA1 separately (page 34), and use the stainless steel set screws, after selecting set screws of the appropriate length for the cylinder series—as shown in the table above.

<Applicable Auto Switch>

Solid state switch ... D-P4DWL

How to Mount and Move the Auto Switch

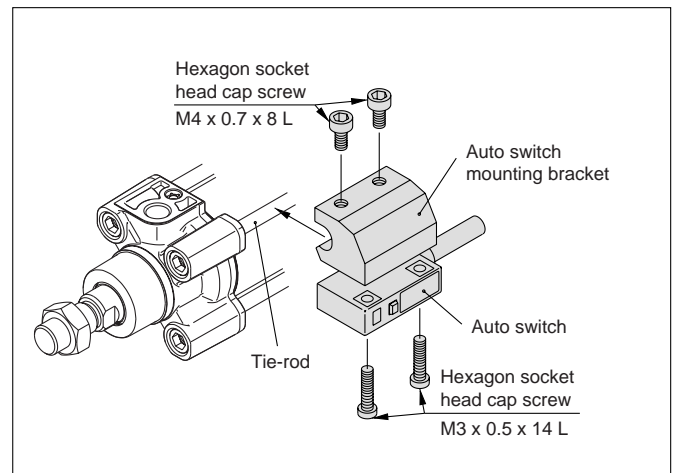

1. Slightly screw the hexagon socket head cap screw (M4 x 0.7 x 8 L) into the M4 tapped portion of auto switch mounting bracket. (2 locations) Use caution that the tip of the hexagon socket head cap screw should not stick out to the concave portion of auto switch mounting bracket.
2. Put a hexagon socket head cap screw (M3 x 0.5 x 14 L) through the auto switch's through-hole (2 locations), and then push it down into the M3 tapped part on the auto switch mounting bracket while turning it lightly.
3. Place the concave part of the auto switch mounting bracket into the cylinder tie-rod, and slide the auto switch mounting bracket in order to set roughly to the detecting position.
4. After reconfirming the detecting position, tighten the M3 mounting screw to secure the auto switch by making the bottom face of auto switch attached to the cylinder tube. (Tightening torque of M3 screw should be 0.5 to 0.7 N·m.)
5. Tighten up M4 screw of auto switch mounting bracket to secure the auto switch mounting bracket. (Ensure that tightening torque of M4 screw should be set 1.0 to 1.2 N·m.)

Auto Switch Mounting Bracket Part No. (Including Bracket, Screw)

Cylinder series	Applicable bore size (mm)						
	32	40	50	63	80	100	125
C96	BMB3T-040	BMB3T-040	BMB3T-050	BMB3T-050	BMB3T-080	BMB3T-080	BAP2T-080

How to Mount and Move the Auto Switch

Mounting Bracket Tie-rod Mounting

<Applicable Auto Switch>

Solid state switch ... D-F59, D-F5P

D-J59, D-J51, D-F5BAL

D-F59W, D-F5PW, D-J59W

D-F59F, D-F5NTL

Reed switch D-A53, D-A54, D-A56, D-A64, D-A67

D-A59W

1. Fix the auto switch on the auto switch mounting bracket with the auto switch mounting screw (M4) and install the set screw.
2. Fit the auto switch mounting bracket into the cylinder tie-rod and then fix the auto switch at the detecting position with the hexagonal wrench. (Be sure to put the auto switch on the surface of cylinder tube.)
3. When changing the detecting position, loosen the set screw to move the auto switch and then re-fix the auto switch on the cylinder tube. (Tightening torque of M4 screw should be 1.0 to 1.2 N·m.)

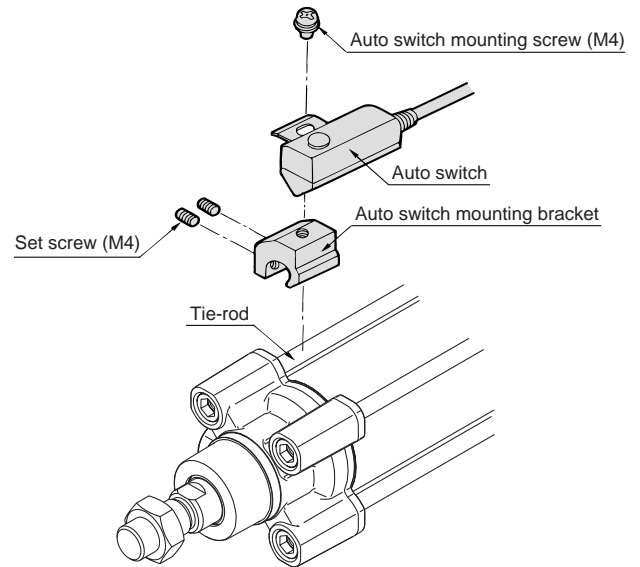

Auto Switch Mounting Bracket Part No. (Including Bracket, Screw, Set Screw)

Cylinder series	Applicable bore size (mm)						
	32	40	50	63	80	100	125
C96	BT-03	BT-03	BT-05	BT-05	BT-06	BT-06	BT-08

[Mounting screws set made of stainless steel]

The following set of mounting screws made of stainless steel is also available. Use it in accordance with the operating environment.

(Please order the auto switch mounting bracket separately, since it is not included.)

BBA1: For D-A5/A6/F5/J5

"D-F5BAL" switch is set on the cylinder with the stainless steel screws above when shipped from factory.

When a switch is shipped independently, "BBA1" screws are attached.

Auto Switch Mounting Screw Set

Part no.	Contents				Applicable auto switch mounting bracket part no.	Applicable auto switch
	No.	Description	Size	Quantity		
BBA1	1	Auto switch mounting screw	M4 x 0.7 x 8L	1	BT-□□	D-A5, A6 D-F5, J5
	2	Set screw	M4 x 0.7 x 6L	2	BT-03, BT-04, BT-05 BT-06, BT-08, BT-12	D-Z7, Z8 D-Y5, Y6, Y7
					BMB4-032, BMB4-050	D-A9 D-M9
					BMB5-032 BA7-040, BA7-063, BA7-080	
	3	Set screw	M4 x 0.7 x 8L	2	BT-16, BT-18A, BT-20	D-A5, A6 D-F5, J5
					BS4-125, BS4-160 BS4-180, BS4-200	D-Z7, Z8 D-Y5, Y6, Y7
BS5-125, BS5-160 BS5-180, BS5-200					D-A9 D-M9	





Safety Instructions

These safety instructions are intended to prevent hazardous situations and/or equipment damage. These instructions indicate the level of potential hazard with the labels of “**Caution**,” “**Warning**” or “**Danger**.” They are all important notes for safety and must be followed in addition to International Standards (ISO/IEC), Japan Industrial Standards (JIS)*1) and other safety regulations*2).

- * 1) ISO 4414: Pneumatic fluid power – General rules relating to systems.
- ISO 4413: Hydraulic fluid power – General rules relating to systems.
- IEC 60204-1: Safety of machinery – Electrical equipment of machines. (Part 1: General requirements)
- ISO 10218-1992: Manipulating industrial robots -Safety.
- JIS B 8370: General rules for pneumatic equipment.
- JIS B 8361: General rules for hydraulic equipment.
- JIS B 9960-1: Safety of machinery – Electrical equipment of machines. (Part 1: General requirements)
- JIS B 8433-1993: Manipulating industrial robots - Safety.
- etc.

* 2) Labor Safety and Sanitation Law, etc.

 **Caution:** Operator error could result in injury or equipment damage.

 **Warning:** Operator error could result in serious injury or loss of life.

 **Danger :** In extreme conditions, there is a possibility of serious injury or loss of life.

Warning

1. The compatibility of the product is the responsibility of the person who designs the equipment or decides its specifications.

Since the product specified here is used under various operating conditions, its compatibility with specific equipment must be decided by the person who designs the equipment or decides its specifications based on necessary analysis and test results. The expected performance and safety assurance of the equipment will be the responsibility of the person who has determined its compatibility with the product. This person should also continuously review all specifications of the product referring to its latest catalog information, with a view to giving due consideration to any possibility of equipment failure when configuring the equipment.

2. Only personnel with appropriate training should operate machinery and equipment.

The product specified here may become unsafe if handled incorrectly. The assembly, operation and maintenance of machines or equipment including our products must be performed by an operator who is appropriately trained and experienced.

3. Do not service or attempt to remove product and machinery/equipment until safety is confirmed.

1. The inspection and maintenance of machinery/equipment should only be performed after measures to prevent falling or runaway of the driven objects have been confirmed.

2. When the product is to be removed, confirm that the safety measures as mentioned above are implemented and the power from any appropriate source is cut, and read and understand the specific product precautions of all relevant products carefully.

3. Before machinery/equipment is restarted, take measures to prevent unexpected operation and malfunction.

4. Contact SMC beforehand and take special consideration of safety measures if the product is to be used in any of the following conditions.

1. Conditions and environments outside of the given specifications, or use outdoors or in a place exposed to direct sunlight.

2. Installation on equipment in conjunction with atomic energy, railways, air navigation, space, shipping, vehicles, military, medical treatment, combustion and recreation, or equipment in contact with food and beverages, emergency stop circuits, clutch and brake circuits in press applications, safety equipment or other applications unsuitable for the standard specifications described in the product catalog.

3. An application which could have negative effects on people, property, or animals requiring special safety analysis.

4. Use in an interlock circuit, which requires the provision of double interlock for possible failure by using a mechanical protective function, and periodical checks to confirm proper operation.



Safety Instructions

Caution

The product is provided for use in manufacturing industries.

The product herein described is basically provided for peaceful use in manufacturing industries.

If considering using the product in other industries, consult SMC beforehand and exchange specifications or a contract if necessary. If anything is unclear, contact your nearest sales branch.

Limited Warranty and Disclaimer/Compliance Requirements

The product used is subject to the following “Limited Warranty and Disclaimer” and “Compliance Requirements”. Read and accept them before using the product.

Limited Warranty and Disclaimer

1. The warranty period of the product is 1 year in service or 1.5 years after the product is delivered.*3)

Also, the product may have specified durability, running distance or replacement parts. Please consult your nearest sales branch.

2. For any failure or damage reported within the warranty period which is clearly our responsibility, a replacement product or necessary parts will be provided.

This limited warranty applies only to our product independently, and not to any other damage incurred due to the failure of the product.

3. Prior to using SMC products, please read and understand the warranty terms and disclaimers noted in the specified catalog for the particular products.

* 3) Vacuum pads are excluded from this 1 year warranty.

A vacuum pad is a consumable part, so it is warranted for a year after it is delivered.

Also, even within the warranty period, the wear of a product due to the use of the vacuum pad or failure due to the deterioration of rubber material are not covered by the limited warranty.

Compliance Requirements

When the product is exported, strictly follow the laws required by the Ministry of Economy, Trade and Industry (Foreign Exchange and Foreign Trade Control Law).



Actuators Precautions 1

Be sure to read this before handling.

Design and Selection

Warning

- 1. There is a danger of sudden action by air cylinders if sliding parts of machinery are twisted, etc., and changes in forces occur.**

In such cases, human injury may occur; e.g., by catching hands or feet in the machinery, or damage to the machinery itself may occur. Therefore, the machine should be designed to avoid such dangers.

- 2. Install a protective cover when there is a risk of human injury**

If a driven object and moving parts of a cylinder pose a danger of human injury, design the structure to avoid contact with the human body.

- 3. Securely tighten all stationary parts and connected parts so that they will not become loose.**

Especially when a cylinder operates with high frequency or is installed where there is a lot of vibration, ensure that all parts remain secure.

- 4. A deceleration circuit may be required.**

When a driven object is operated at high speed or the load is heavy, a cylinder's cushion will not be sufficient to absorb the impact. Install a deceleration circuit to reduce the speed before cushioning to relieve the impact. In this case, the rigidity of the machinery should also be examined.

- 5. Consider a possible drop in operating pressure due to a power outage, etc.**

When a cylinder is used in a clamping mechanism, there is a danger of work pieces dropping if there is a decrease in clamping force due to a drop in circuit pressure caused by a power outage, etc. Therefore, safety equipment should be installed to prevent damage to machinery and/or human injury. Suspension mechanisms and lifting devices also require consideration for drop prevention.

- 6. Consider a possible loss of power source.**

Measures should be taken to protect against human injury and equipment damage in the event that there is a loss of power to equipment controlled by air pressure, electricity or hydraulics, etc.

- 7. Design circuitry to prevent sudden lurching of driven objects.**

When a cylinder is driven by an exhaust center type directional control valve or when starting up after residual pressure is exhausted from the circuit, etc., the piston and its driven object will lurch at high speed if pressure is applied to one side of the cylinder because of the absence of air pressure inside the cylinder. Therefore, select equipment and design circuits to prevent sudden lurching, because there is a danger of human injury and/or damage to equipment when this occurs.

- 8. Consider emergency stops.**

Design so that human injury and/or damage to machinery and equipment will not be caused when machinery is stopped by a safety device under abnormal conditions, such as a power outage or a manual emergency stop.

- 9. Consider the action when operation is restarted after an emergency stop or abnormal stop.**

Design the machinery so that human injury or equipment damage will not occur upon restart of operation. When the cylinder has to be reset at the starting position, install safe manual control equipment.

Warning

- 1. Confirm the specifications.**

The products advertised in this catalog are designed according to use in industrial compressed air systems. If the products are used in conditions where pressure, temperature, etc., are out of specification, damage and/or malfunction may be caused. Do not use in these conditions. (Refer to the specifications.) Consult SMC if you use a fluid other than compressed air.

- 2. Intermediate stops**

When intermediate stopping of a cylinder piston is performed with a 3 position closed center type directional control valve, it is difficult to achieve stopping positions as accurate and precise as with hydraulic pressure due to the compressibility of air.

Furthermore, since valves and cylinders, etc., are not guaranteed for zero air leakage, it may not be possible to hold a stopped position for an extended period of time. Contact SMC in case it is necessary to hold a stopped position for an extended period.

Caution

- 1. Operate within the limits of the maximum usable stroke.**

The piston rod will be damaged if operated beyond the maximum stroke. Refer to the air cylinder model selection procedure for the maximum usable stroke.

- 2. Operate the piston within a range such that collision damage will not occur at the stroke end.**

Operate within a range such that damage will not occur when the piston having inertial force stops by striking the cover at the stroke end. Refer to the cylinder model selection procedure for the range within which damage will not occur.

- 3. Use a speed controller to adjust the cylinder drive speed, gradually increasing from a low speed to the desired speed setting.**

- 4. Provide intermediate supports for long stroke cylinders.**

Provide intermediate supports for cylinders with long strokes to prevent rod damage due to sagging of the rod, deflection of the tube, vibration and external loads, etc.

It is assumed the persons determining the stroke requirements have technical training and expertise in the design limitations of pneumatic equipment and are aware that death, personal injury, and property damage may result from the improper use of these products. Proper use is the users responsibility.



Actuators Precautions 2

Be sure to read this before handling.

Mounting

⚠ Caution

1. **Be certain to align the rod axis with the load and direction of movement when connecting.**

When not properly aligned, the rod and tube may be twisted, and damage may be caused due to wear on areas such as the inner tube surface, bushings, rod surface and seals.

2. **When an external guide is used, connect the rod end and the load in such a way that there is no interference at any point within the stroke.**
3. **Do not scratch or gouge the sliding parts of the cylinder tube or piston rod, etc., by striking or grasping them with other objects.**

Cylinder bores are manufactured to precise tolerances, so that even a slight deformation may cause malfunction. Also, scratches or gouges, etc., in the piston rod may lead to damaged seals and cause air leakage.

4. **Prevent the seizure of rotating parts.**

Prevent the seizure of rotating parts (pins, etc.) by applying grease.

5. **Do not use until you can verify that equipment can operate properly.**

Verify correct mounting by appropriate function and leakage inspections after compressed air and power are connected following mounting, maintenance or conversions.

6. **Operating manual**

The product should be mounted and operated after thoroughly reading the manual and understanding its contents.

Keep the operating manual where it can be referred to as needed.

7. **Preparation before piping**

Before piping is connected, it should be thoroughly blown out with air (flushing) or washed to remove chips, cutting oil and other debris from inside the pipe.

8. **Wrapping of pipe tape**

When screwing together pipes and fittings, etc., be certain that chips from the pipe threads and sealing material do not get inside the piping.

Also, when pipe tape is used, leave 1.5 to 2 thread ridges exposed at the end of the threads.

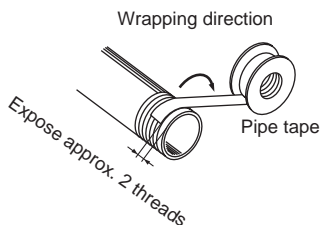

Cushion

⚠ Caution

1. **Readjust using the cushion needle.**

Cushion is adjusted at the factory, however, the cushion needle on the cover should be readjusted when the product is put into service, based upon factors such as the size of the load and the operating speed. When the cushion needle is turned clockwise, the restriction becomes smaller and the cushion's effectiveness is increased. Tighten the lock nut securely after adjustment is performed.

2. **Do not operate with the cushion needle in a fully closed condition.**

This will cause damage to the seals.

⚠ Warning

1. **Use clean air.**

Do not use compressed air which includes chemicals, synthetic oils containing organic solvents, salt or corrosive gases, etc., as it can cause damage or malfunction.

⚠ Caution

1. **Install air filters.**

Install air filters at the upstream side of valves. The filtration degree should be 5 μm or finer.

2. **Install an after-cooler, air dryer or water separator, etc.**

Air that includes excessive drainage may cause malfunction of valves and other pneumatic equipment. To prevent this, install an after-cooler, air dryer or water separator, etc.

3. **Use the product within the specified range of fluid and ambient temperature.**

Take measures to prevent freezing, since moisture in circuits can be frozen below 5°C, and this may cause damage to seals and lead to malfunction.

Refer to SMC "Best Pneumatics 2004" Vol.14 catalog for further details on compressed air quality.

Maintenance

⚠ Warning

1. **Removal of equipment, and supply/exhaust of compressed air.**

When equipment is removed, first check measures to prevent dropping of driven objects and run-away of equipment, etc. Then, cut off the supply pressure and electric power, and exhaust all compressed air from the system.

When machinery is restarted, proceed with caution after confirming measures to prevent cylinder from lurching.

⚠ Caution

1. **Drain flushing**

Remove drainage from air filters regularly. (Refer to the specifications.)



Series CP96/C96 Auto Switches Precautions 1

Be sure to read this before handling.

Design and Selection

⚠ Warning

1. Confirm the specifications.

Read the specifications carefully and use this product appropriately. The product may be damaged or malfunction if it is used outside the range of specifications for current load, voltage, temperature or impact.

2. Cautions for use in an interlock circuit

When an auto switch is used for an interlock signal requiring high reliability, devise a double interlock system to avoid trouble by providing a mechanical protection function, or by also using another switch (sensor) together with the auto switch.

Also, perform periodic maintenance and confirm proper operation.

3. Do not make any modifications (including exchanging the printed circuit boards) to the product.

It may cause human injuries and accidents.

⚠ Caution

1. Pay attention to the length of time that a switch is ON at an intermediate stroke position.

When an auto switch is placed at an intermediate position of the stroke and a load is driven at the time the piston passes, the auto switch will operate, but if the speed is too great the operating time will be shortened and the load may not operate properly. The maximum detectable piston speed is:

$$V \text{ (mm/s)} = \frac{\text{Auto switch operating range (mm)}}{\text{Time load applied (ms)}} \times 1000$$

In cases of high piston speed, the use of an auto switch (F5NTL) with a built-in OFF delay timer (≈ 200 ms) makes it possible to extend the load operating time.

⚠ Caution

2. Keep wiring as short as possible.

<Reed switches>

As the length of the wiring to a load gets longer, the rush current at switching ON becomes greater, and this may shorten the product's life. (The switch will stay ON all the time.)

1) Use a contact protection box when the wire length is 5 m or longer.

2) Even if an auto switch has a built-in contact protection circuit, when the wiring is more than 30 m long, it is not able to adequately absorb the rush current and its life may be reduced. It is again necessary to connect a contact protection box in order to extend its life. Contact SMC in this case.

<Solid state switches>

3) Although wire length should not affect switch function, use a wire 100 m or shorter.

If the wiring is longer it will likely increase noise although the length is less than 100 m.

When the wire length is long, we recommend attaching the ferrite core to the both ends of the cable to prevent excess noise.

A contact protection box is not necessary for solid state switches due to the nature of this product construction.

3. Do not use a load that generates surge voltage. If a surge voltage is generated, the discharge occurs at the contact, possibly resulting in the shortening of product life.

<Reed switches>

If driving a load such as a relay that generates a surge voltage, use an auto switch with built-in contact protection circuit or use a contact protection box.

<Solid state switches>

Although a zener diode for surge protection is connected at the output side of a solid state auto switch, damage may still occur if the surge is applied repeatedly. When a load, such as a relay or solenoid which generates surge is directly driven, use a type of switch with a built-in surge absorbing element.

4. Take precautions when multiple cylinders (actuators) are used close together.

When multiple auto switch cylinders (actuators) are used in close proximity, magnetic field interference may cause the auto switches to malfunction. Maintain a minimum cylinder separation of 40 mm.

(When the allowable interval is specified for each cylinder series, use the indicated value.) The auto switches may malfunction due to the interference from the magnetic fields.

Use of a magnetic screen plate (MU-S025) or magnetic screen tape can reduce the interference of magnetic force.



Series CP96/C96 Auto Switches Precautions 2

Be sure to read this before handling.

Design and Selection

⚠ Caution

5. Pay attention to the internal voltage drop of the auto switch.

<Reed switches>

- 1) Auto switches with an indicator light (Except D-A96, Z76, A56)
 - If auto switches are connected in series as shown below, take note that there will be a large voltage drop because of internal resistance in the light emitting diodes. (Refer to the internal voltage drop in the auto switch specifications.)
[The voltage drop will be "n" times larger when "n" auto switches are connected.]
Even though an auto switch operates normally, the load may not operate.

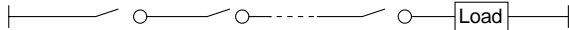

- In the same way, when operating under a specified voltage, although an auto switch may operate normally, the load may not operate. Therefore, the formula below should be satisfied after confirming the minimum operating voltage of the load.

$$\text{Supply voltage} - \text{Internal voltage drop of auto switch} > \text{Minimum operating voltage of load}$$

- 2) If the internal resistance of a light emitting diode causes a problem, select an auto switch without an indicator light (Model D-A90, A90V, Z80).

<Solid state switches>

- 3) Generally, the internal voltage drop will be greater with a 2-wire solid state auto switch than with a reed switch. Take the same precautions as in 1).
Also, note that a 12 VDC relay is not applicable.

6. Pay attention to leakage current.

<Solid state switches>

With a 2-wire solid state auto switch, current (leakage current) flows to the load to operate the internal circuit even when in the OFF state.

$$\text{Operating current of load (OFF condition)} > \text{Leakage current}$$

If the criteria given in the above formula are not met, it will not reset correctly (stays ON). Use a 3-wire switch if this specification will not be satisfied.

Moreover, leakage current flow to the load will be "n" times larger when "n" auto switches are connected in parallel.

7. Ensure sufficient clearance for maintenance activities.

When designing an application, be sure to allow sufficient clearance for maintenance and inspections.

8. When multiple auto switches are required

"n" indicates the number of auto switch which can be physically mounted. Detection intervals depends on the auto switch mounting structure and set position therefore some required interval and set positions may not be available.

⚠ Caution

9. Limitations of detectable positioning

When using certain mounting brackets, the surface and position where an auto switch can be mounted maybe restricted due to physical interference. For example, when using some bracket types the auto switch cannot be surface mounted at the bottom side of foot bracket, etc.
Select the set position of the auto switch so that it does not interfere with the rear plate of the cylinder.

10. Use the cylinder and auto switch in proper combination.

The auto switch is pre-adjusted to activate properly for an auto-switch-capable SMC cylinder.

If the auto switch is mounted improperly, used for another brand of cylinder or used after the alternation of the machine installation, the auto switch may not activate properly.

11. Confirm the applicable auto switch of the CP96 series.

D-Y59A, Y69A, Y7P, Y7□W, Z7□, Z80 type cannot be mounted on the CP96 series. Moreover, D-M9□□ and A9□ type cannot be mounted on square groove of the CP96 series.

Mounting and Adjustment

⚠ Caution

1. Do not drop or bump.

Do not drop, bump or apply excessive impacts (300 m/s² or more for reed switches and 1000 m/s² or more for solid state switches) while handling. Although the body of the auto switch may not be damaged, the inside of the auto switch could be damaged and cause a malfunction.

2. Mount auto switches using the proper tightening torque.

If an auto switch is tightened beyond the range of tightening torque, the auto switch mounting screws, auto switch mounting brackets or auto switch may be damaged.

On the other hand, tightening below the range of tightening torque may allow the auto switch to slip out of position.

3. Do not carry a cylinder by the auto switch lead wires.

Never carry a cylinder by its lead wires. This may not only cause broken lead wires, but it may cause internal elements of the auto switch to be damaged by the stress.

4. Fix the auto switch with appropriate screw installed on the switch body. If using other screws, auto switch may be damaged.



Series CP96/C96 Auto Switches Precautions 3

Be sure to read this before handling.

Wiring

⚠ Caution

1. Confirm proper insulation of wiring.

Be certain that there is no faulty wiring insulation (contact with other circuits, ground fault, improper insulation between terminals, etc.). Damage may occur due to excess current flow into a switch.

2. Do not wire with power lines or high voltage lines.

Wire separately from power lines or high voltage lines, avoiding parallel wiring or wiring in the same conduit with these lines. Control circuits containing auto switches may malfunction due to noise from these other lines.

3. Avoid repeatedly bending or stretching lead wires.

Broken lead wires will result from repeatedly applying bending stress or stretching force to the lead wires.

Stress and tensile force applied to the connection between the cable and auto switch increases the possibility of disconnection. Fix the cable in the middle so that it is not movable in the area where it connects with the auto switch.

4. Be sure to connect the load before power is applied.

<2-wire type>

If the power is turned ON when an auto switch is not connected to a load, the auto switch will be instantly damaged because of excess current.

It is the same as when the 2-wire brown cord (+, output) is directly connected to the (+) power supply terminal.

5. Do not allow short circuit of loads.

<Reed switches>

If the power is turned ON with a load in a short circuited condition, the auto switch will be instantly damaged because of excess current flow into the switch.

<Solid state switches>

All models of D-M9□(V) except D-M9□W(V) and PNP output type auto switches do not have built-in short circuit protection circuits.

Note that if a load is short circuited, the auto switch will be instantly damaged as in the case of reed switches.

Take special care to avoid reverse wiring with the brown power supply line and the black output line on 3-wire type auto switches.

⚠ Caution

6. Avoid incorrect wiring.

<Reed switches>

A 24 VDC auto switch with indicator light has polarity. The brown lead wire or terminal No. 1 is (+), and the blue lead wire or terminal No. 2 is (-).

1) If connections are reversed, an auto switch will operate, however, the light emitting diode will not light up.

Also, note that a current greater than that specified will damage a light emitting diode and it will no longer operate.

Applicable model: D-A93, A93V, Z73, A53, A54, A44, A33, A34

2) When using a 2-color indication type auto switch (D-A59W), the auto switch will constantly remain ON if the connections are reversed.

<Solid state switches>

1) If connections are reversed on a 2-wire type auto switch, the auto switch will not be damaged if protected by a protection circuit, but the auto switch will always stay in an ON state. However, it is still necessary to avoid reversed connections, since the auto switch could be damaged by a load short circuit in this condition.

2) If connections are reversed (power supply line + and power supply line -) on a 3-wire type auto switch, the auto switch will be protected by a protection circuit. However, if the power supply line (+) is connected to the blue wire and the power supply line (-) is connected to the black wire, the auto switch will be damaged.

7. When the cable sheath is stripped, confirm the stripping direction. The insulator may be split or damaged depending on the direction. (D-M9□ only)

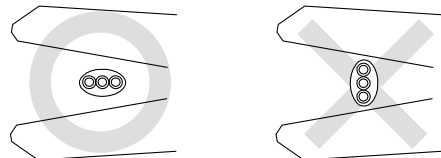

Recommended Tool

Model name	Model no.
Wire stripper	D-M9N-SWY

* Stripper for a round cable (ø2.0) can be used for a 2-wire type cable.

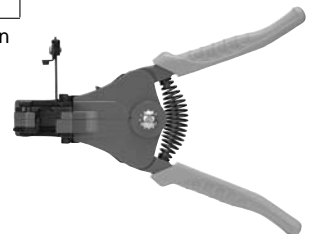



Series CP96/C96 Auto Switches Precautions 4

Be sure to read this before handling.

Operating Environment

⚠ Warning

1. Never use in an atmosphere of explosive gases.

The structure of auto switches is not intended to prevent explosion. Never use in an atmosphere with an explosive gas since this may cause a serious explosion. Consult SMC concerning ATEX compliant products.

⚠ Caution

1. Do not use in an area where a magnetic field is generated.

Auto switches will malfunction or magnets inside cylinders will become demagnetized. (Consult SMC regarding the availability of a magnetic field resistant auto switch.)

2. Do not use in an environment where the auto switch will be continually exposed to water.

Although auto switches satisfy IEC standard IP67 construction except for some models (D-A3□, A44, G39, K39) do not use auto switches in applications where continually exposed to water splash or spray. Poor insulation or swelling of the potting resin inside auto switches may cause malfunction.

3. Do not use in an environment with oil or chemicals.

Consult SMC if auto switches will be used in an environment with coolant, cleaning solvent, various oils or chemicals. If auto switches are used under these conditions for even a short time, they may be adversely affected by improper insulation, malfunction due to swelling of the potting resin, or hardening of the lead wires.

4. Do not use in an environment with temperature cycles.

Consult SMC if auto switches are used where there are temperature cycles other than normal temperature changes, as there may be adverse effects inside the auto switches.

5. Do not use in an environment where there is excessive impact shock.

<Reed switches>

When excessive impact (300 m/s² or more) is applied to a reed switch during operation, the contact point will malfunction and generate or cut off a signal momentarily (1 ms or less). Consult SMC regarding the need to use a solid state switch depending upon the environment.

6. Do not use in an area where surges are generated.

<Solid state switches>

When there are units (solenoid type lifter, high frequency induction furnace, motor, radio equipment etc.) which generate a large amount of surge in the area around cylinders with solid state auto switches, this may cause deterioration or damage to the auto switch. Avoid sources of surge generation and disorganized lines.

⚠ Caution

7. Avoid accumulation of iron waste or close contact with magnetic substances.

When a large amount of iron waste such as machining chips or spatter is accumulated, or a magnetic substance (something attracted by a magnet) is brought into close proximity with an auto switch cylinder, it may cause the auto switch to malfunction due to a loss of the magnetic force inside the cylinder.

8. Consult SMC concerning water resistance, elasticity of lead wires, usage at welding sites, etc.

9. Do not use in direct sunlight.

10. Do not mount the product in locations where it is exposed to radiant heat.

Maintenance

⚠ Warning

1. Removal of equipment, and supply/exhaust of compressed air

Before any machinery or equipment is removed, first ensure that the appropriate measures are in place to prevent the fall or erratic movement of driven objects and equipment, then cut off the electric power and reduce the pressure in the system to zero. Only then should you proceed with the removal of any machinery and equipment.

When machinery is restarted, proceed with caution after confirming that appropriate measures are in place to prevent actuators from moving suddenly.

⚠ Caution

1. Perform the following maintenance periodically in order to prevent possible danger due to unexpected auto switch malfunction.

1) Secure and tighten auto switch mounting screws.

If screws become loose or the mounting position is dislocated, retighten them after readjusting the mounting position.

2) Confirm that there is no damage to lead wires.

To prevent faulty insulation, replace auto switches or repair lead wires, etc., if damage is discovered.

3) Confirm the lighting of the green light on the 2-color indicator type auto switch.

Confirm that the green LED is on when stopped at the established position. If the red LED is on, the mounting position is not appropriate. Readjust the mounting position until the green LED lights up.

SMC'S GLOBAL MANUFACTURING, DISTRIBUTION AND SERVICE NETWORK

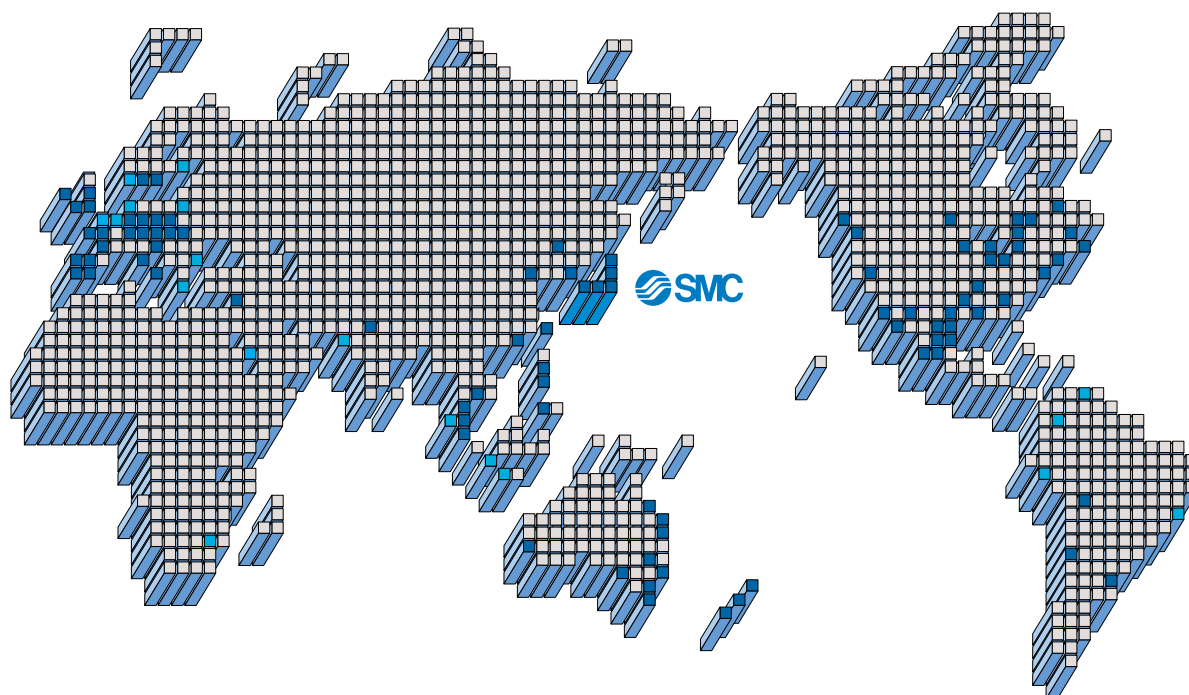

EUROPE

AUSTRIA

SMC Pneumatik GmbH (Austria)

BELGIUM

SMC Pneumatics N.V./S.A.

BULGARIA

SMC Industrial Automation Bulgaria Eood

CROATIA

SMC Industrijska Automatika d.o.o.

CZECH REPUBLIC

SMC Industrial Automation CZ s.r.o.

DENMARK

SMC Pneumatik A/S

ESTONIA

SMC Pneumatics Estonia OÜ

FINLAND

SMC Pneumatics Finland Oy

FRANCE

SMC Pneumatique SA

GERMANY

SMC Pneumatik GmbH

GREECE

SMC Hellas E.P.E.

HUNGARY

SMC Hungary Ipari Automatizálási Kft.

IRELAND

SMC Pneumatics (Ireland) Ltd.

ITALY

SMC Italia S.p.A.

LATVIA

SMC Pnuematics Latvia SIA

LITHUANIA

UAB "SMC Pneumatics"

NETHERLANDS

SMC Pneumatics B.V.

NORWAY

SMC Pneumatics Norway AS

POLAND

SMC Industrial Automation Polska Sp.z.o.o.

ROMANIA

SMC Romania S.r.l.

RUSSIA

SMC Pneumatik LLC

SLOVAKIA

SMC Priemyselná Automatizácia Spol s.r.o.

SLOVENIA

SMC Industrijska Avtomatika d.o.o.

SPAIN/PORTUGAL

SMC España S.A.

SWEDEN

SMC Pneumatics Sweden AB

SWITZERLAND

SMC Pneumatik AG

U.K.

SMC Pneumatics (U.K.) Ltd.

ASIA

CHINA

SMC (China) Co., Ltd.

HONG KONG

SMC Pneumatics (Hong Kong) Ltd.

INDIA

SMC Pneumatics (India) Pvt. Ltd.

MALAYSIA

SMC Pneumatics (S.E.A.) Sdn. Bhd.

PHILIPPINES

Shoketsu SMC Corporation

SINGAPORE

SMC Pneumatics (S.E.A.) Pte. Ltd.

SOUTH KOREA

SMC Pneumatics Korea Co., Ltd.

TAIWAN

SMC Pneumatics (Taiwan) Co., Ltd.

THAILAND

SMC (Thailand) Ltd.

NORTH AMERICA

CANADA

SMC Pneumatics (Canada) Ltd.

MEXICO

SMC Corporation (Mexico), S.A. de C.V.

U.S.A.

SMC Corporation of America

SOUTH AMERICA

ARGENTINA

SMC Argentina S.A.

BOLIVIA

SMC Pneumatics Bolivia S.r.l.

BRAZIL

SMC Pneumáticos do Brasil Ltda

CHILE

SMC Pneumatics (Chile) S.A.

VENEZUELA

SMC Neumatica Venezuela S.A.

OCEANIA

AUSTRALIA

SMC Pneumatics (Australia) Pty. Ltd.

NEW ZEALAND

SMC Pneumatics (N.Z.) Ltd.

SMC Corporation

Akihabara UDX 15F,
4-14-1, Sotokanda, Chiyoda-ku, Tokyo 101-0021, JAPAN

Phone: 03-5207-8249 Fax: 03-5298-5362

URL <http://www.smcworld.com>

© 2008 SMC Corporation All Rights Reserved

Specifications are subject to change without prior notice
and any obligation on the part of the manufacturer.

D-DN

1st printing MP printing MP 13500DN Printed in Japan.

This catalog is printed on recycled paper with concern for the global environment.